

CYLINDRICAL ROLLER BEARINGS

SINGLE-ROW CYLINDRICAL ROLLER BEARINGS	Bore Diameter 20 – 65mm	B 88
	Bore Diameter 70 – 160mm	B 94
	Bore Diameter 170 – 500mm	B102
L-SHAPED THRUST COLLARS FOR CYLINDRICAL ROLLER BEARINGS	Bore Diameter 20 – 320mm	B106
DOUBLE-ROW CYLINDRICAL ROLLER BEARINGS	Bore Diameter 25 – 360mm	B110

Four-Row Cylindrical Roller Bearings are described on Pages B334 to B343.

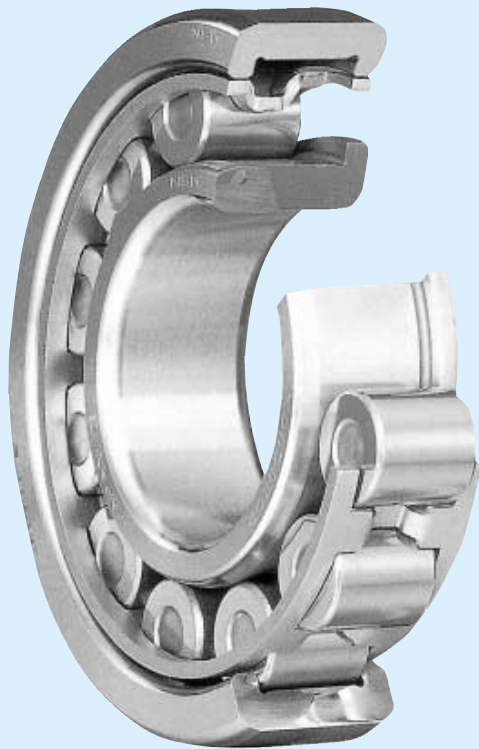

DESIGN, TYPES, AND FEATURES

Depending on the existence of ribs on their rings, Cylindrical Roller Bearings are classified into the following types.

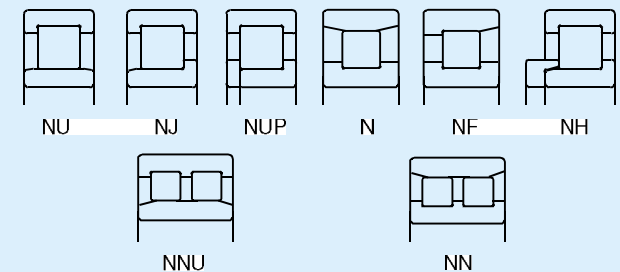

Types NU, N, NNU, and NN are suitable as free-end bearings. Types NJ and NF can sustain limited axial loads in one direction. Types NH and NUP can be used as fixed-end bearings.

NH-type cylindrical roller bearings consist of the NJ-type cylindrical roller bearings and HJ-type L-shaped thrust collars (See Page B106 to B109).

The inner ring loose rib of a NUP-type cylindrical roller bearing should be mounted so that the marked side is on the outside.

Use pressed, machined, or molded cages for standard cylindrical roller bearings as shown in Table 1.

Table 1 Standard Cages for Cylindrical Roller Bearings

Series	Standard Cages for Cylindrical Roller Bearings		
	Pressed Steel Cages (W)	Machined Brass Cages (M)	Molded Polyamide Cages (T)
NU10**	—	1005 – 10/500	—
N2**	204 – 230	232 – 264	—
NU2**	214 – 230	232 – 264	—
NU2**E	205E – 213E	214E – 240E	204E
NU2**	2204 – 2230	2232 – 2252	—
NU2**E	—	2222E – 2240E	2204E – 2220E
N3**	304 – 324	326 – 352	—
NU3**	312 – 330	332 – 352	—
NU3**E	305E – 311E	312E – 340E	304E
NU23**	2304 – 2320	2322 – 2340	—
NU23**E	—	2322E – 2340E	2304E – 2320E
NU4**	405 – 416	417 – 430	—

The basic load ratings listed in the bearing tables are based on the Cage Classification in Table 1.

For a given bearing number, if the type of cage is not the standard one, the number of rollers may vary; in such a case, the load rating will differ from the one listed in the bearing tables.

Among the NN Type of double-row bearings, there are many of high precision that have tapered bores, and they are primarily used in the main spindles of machine tools. Their cages are either molded polyphenylenesulfide (PPS) or machined brass.

PRECAUTIONS FOR USE OF CYLINDRICAL ROLLER BEARINGS

If the load on cylindrical roller bearings becomes too small during operation, slippage between the rollers and raceways occurs, which may result in smearing. Especially with large bearings since the weight of the roller and cage is high.

In case of strong shock loads or vibration, pressed-steel cages are sometimes inadequate.

If very small bearing load or strong shock loads or vibration are expected, please consult with NSK for selection of the bearings.

Bearings with molded polyamide cages (ET type) can be used continuously at temperatures between -40 and 120°C. If the bearings are used in gear oil, nonflammable hydraulic oil, or ester oil at a high temperature over 100°C, please contact NSK beforehand.

TOLERANCES AND RUNNING ACCURACY

CYLINDRICAL ROLLER BEARINGSTable 8.2 (Pages A60 to A63)

DOUBLE-ROW CYLINDRICAL ROLLER BEARINGSTable 8.2 (Pages A60 to A63)

Table 2 Tolerances for Roller Inscribed Circle Diameter F_w and Roller Circumscribed Circle Diameter E_w of Cylindrical Roller Bearings Having Interchangeable Rings Units : μm

Nominal Bore Diameter d (mm)	Tolerances for F_w of types NU, NJ, NUP, NH, and NNU ΔF_w			Tolerances for E_w of types N, NF, and NN ΔE_w		
	over	incl.	high	low	high	low
—	20		+10	0	0	-10
20	50		+15	0	0	-15
50	120		+20	0	0	-20
120	200		+25	0	0	-25
200	250		+30	0	0	-30
250	315		+35	0	0	-35
315	400		+40	0	0	-40
400	500		+45	0	—	—

RECOMMENDED FITS

CYLINDRICAL ROLLER BEARINGSTable 9.2 (Page A84)
Table 9.4 (Page A85)

DOUBLE-ROW CYLINDRICAL ROLLER BEARINGSTable 9.2 (Page A84)
Table 9.4 (Page A85)

INTERNAL CLEARANCES

CYLINDRICAL ROLLER BEARINGSTable 9.14 (Page A91)
DOUBLE-ROW CYLINDRICAL ROLLER BEARINGSTable 9.14 (Page A91)

PERMISSIBLE MISALIGNMENT

The permissible misalignment of cylindrical roller bearings varies depending on the type and internal specifications, but under normal loads, the angles are approximately as follows:

- Cylindrical Roller Bearings of width series 0 or 10.0012 radian (2')
- Cylindrical Roller Bearings of width series 20.0006 radian (2')

For double-row cylindrical roller bearings, nearly no misalignment is allowed.

LIMITING SPEEDS

The limiting speeds listed in the bearing tables should be adjusted depending on the bearing load conditions. Also, higher speeds are attainable by making changes in the lubrication method, cage design, etc. Refer to Page A37 for detailed information.

SINGLE-ROW CYLINDRICAL ROLLER BEARINGS

Bore Diameter 20 – 35 mm

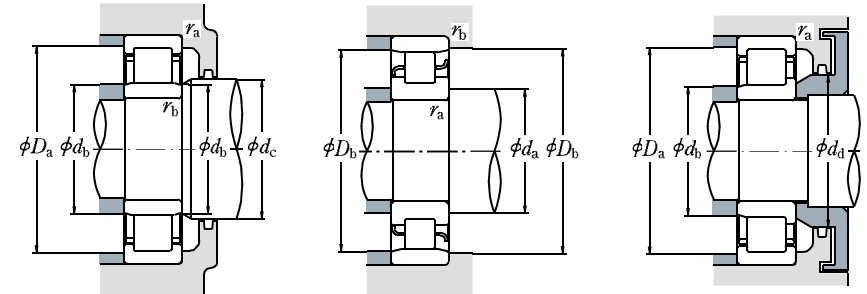
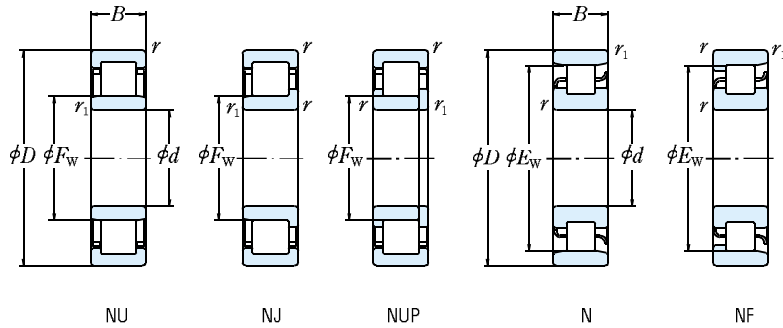

d	Boundary Dimensions (mm)						Basic Load Ratings (N)		Limiting Speeds ⁽¹⁾ (min^{-1})		
	D	B	r min.	r_1 min.	F_W	E_W	C_r	C_{0r}	Grease	Oil	
20	47	14	1	0.6	—	40	15 400	12 700	15 000	18 000	
	47	14	1	0.6	26.5	—	25 700	22 600	13 000	16 000	
	47	18	1	0.6	27	—	20 700	18 400	13 000	16 000	
	47	18	1	0.6	26.5	—	30 500	28 300	13 000	16 000	
	52	15	1.1	0.6	—	44.5	21 400	17 300	12 000	15 000	
	52	15	1.1	0.6	—	27.5	31 500	26 900	12 000	15 000	
	52	21	1.1	0.6	—	28.5	30 500	27 200	11 000	14 000	
	52	21	1.1	0.6	—	27.5	42 000	39 000	11 000	14 000	
	25	47	12	0.6	0.3	30.5	—	14 300	13 100	15 000	18 000
		52	15	1	0.6	—	45	17 700	15 700	13 000	16 000
52		15	1	0.6	—	31.5	29 300	27 700	12 000	14 000	
52		18	1	0.6	31.5	—	35 000	34 500	12 000	14 000	
62		17	1.1	1.1	—	53	29 300	25 200	10 000	13 000	
62		17	1.1	1.1	—	34	41 500	37 500	10 000	12 000	
62		24	1.1	1.1	34	—	57 000	56 000	9 000	11 000	
80		21	1.5	1.5	38.8	62.8	46 500	40 000	9 000	11 000	
30		55	13	1	0.6	36.5	48.5	19 700	19 600	12 000	15 000
		62	16	1	0.6	—	53.5	24 900	23 300	11 000	13 000
	62	16	1	0.6	—	37.5	39 000	37 500	9 500	12 000	
	62	20	1	0.6	37.5	—	49 000	50 000	9 500	12 000	
	72	19	1.1	1.1	—	62	38 500	35 000	8 500	11 000	
	72	19	1.1	1.1	—	40.5	53 000	50 000	8 500	10 000	
	72	27	1.1	1.1	40.5	—	74 500	77 500	8 000	9 500	
	90	23	1.5	1.5	45	73	62 500	55 000	7 500	9 500	
	35	62	14	1	0.6	42	55	22 600	23 200	11 000	13 000
		72	17	1.1	0.6	—	61.8	35 500	34 000	9 500	11 000
72		17	1.1	0.6	—	44	50 500	50 000	8 500	10 000	
72		23	1.1	0.6	44	—	61 500	65 500	8 500	10 000	
80		21	1.5	1.1	—	68.2	49 500	47 000	8 000	9 500	
80		21	1.5	1.1	—	46.2	66 500	65 500	7 500	9 500	
80		31	1.5	1.1	46.2	—	93 000	101 000	6 700	8 500	
100		25	1.5	1.5	53	83	75 500	69 000	6 700	8 000	

Notes (1) The limiting speeds listed above apply to bearings with machined cages (No suffix). For bearings with pressed cages, reduce the limiting speed by 20%. (Not applicable to bearing numbers with an EM, EW, or ET suffix.)
 (2) The bearings with suffix ET have polyamide cage. The maximum operating temperature should be less than 120°C.

Bearing Numbers ⁽²⁾	Abutment and Fillet Dimensions (mm)										Mass (kg) approx.				
	NU ⁽³⁾	NJ	NUP	N	NF	$d_a^{(4)}$ min.	d_b min.	$d_b^{(5)}$ max.	d_c min.	d_a min.		$D_a^{(4)}$ max.	D_b max.	D_b min.	r_a max.
N 204	—	—	—	N	NF	25	—	—	—	—	—	43	42	1	0.6
NU 204 ET	NU	NJ	NUP	—	—	25	24	25	29	32	42	—	—	1	0.6
NU2204	—	—	—	—	—	25	24	25	29	32	42	—	—	1	0.6
NU2204 ET	NU	NJ	NUP	—	—	25	24	25	29	32	42	—	—	1	0.6
N 304	—	—	—	N	NF	26.5	—	—	—	—	—	48	46	1	0.6
NU 304 ET	NU	NJ	NUP	—	—	26.5	24	26	30	33	45.5	—	—	1	0.6
NU2304	—	—	—	—	—	26.5	24	27	30	33	45.5	—	—	1	0.6
NU2304 ET	NU	NJ	NUP	—	—	26.5	24	26	30	33	45.5	—	—	1	0.6
NU1005	NU	—	—	—	—	—	27	30	32	—	43	—	—	0.6	0.3
N 205	—	—	—	N	NF	30	—	—	—	—	—	48	46	1	0.6
NU 205 EW	NU	NJ	NUP	—	—	30	29	30	34	37	47	—	—	1	0.6
NU2205 ET	NU	NJ	NUP	—	—	30	29	30	34	37	47	—	—	1	0.6
N 305	—	—	—	N	NF	31.5	—	—	—	—	—	55.5	50	1	1
NU 305 EW	NU	NJ	NUP	—	—	31.5	31.5	32	37	40	55.5	—	—	1	1
NU2305 ET	NU	NJ	NUP	—	—	31.5	31.5	32	37	40	55.5	—	—	1	1
NU 405	NU	NJ	—	N	NF	33	33	37	41	46	72	72	64	1.5	1.5
NU1006	NU	—	—	N	—	35	34	36	38	—	50	51	49	1	0.5
N 206	—	—	—	N	NF	35	—	—	—	—	—	58	56	1	0.6
NU 206 EW	NU	NJ	NUP	—	—	35	34	36	40	44	57	—	—	1	0.6
NU2206 ET	NU	NJ	NUP	—	—	35	34	36	40	44	57	—	—	1	0.6
N 306	—	—	—	N	NF	36.5	—	—	—	—	—	65.5	64	1	1
NU 306 EW	NU	NJ	NUP	—	—	36.5	36.5	39	44	48	65.5	—	—	1	1
NU2306 ET	NU	NJ	NUP	—	—	36.5	36.5	39	44	48	65.5	—	—	1	1
NU 406	NU	NJ	—	N	NF	38	38	43	47	52	82	82	75	1.5	1.5
NU1007	NU	NJ	—	N	—	40	39	41	44	—	57	58	56	1	0.5
N 207	—	—	—	N	NF	41.5	—	—	—	—	—	68	64	1	0.6
NU 207 EW	NU	NJ	NUP	—	—	41.5	39	42	46	50	65.5	—	—	1	0.6
NU2207 ET	NU	NJ	NUP	—	—	41.5	39	42	46	50	65.5	—	—	1	0.6
N 307	—	—	—	N	NF	43	—	—	—	—	—	73.5	70	1.5	1
NU 307 EW	NU	NJ	NUP	—	—	41.5	41.5	44	48	53	72	—	—	1.5	1
NU2307 ET	NU	NJ	NUP	—	—	43	41.5	44	48	53	72	—	—	1.5	1
NU 407	NU	NJ	—	N	NF	43	43	51	55	61	92	92	85	1.5	1.5

Notes (3) When L-shaped thrust collars (See section for L-Shaped Thrust Collars starting on page B104) are used, the bearings become the NH type.
 (4) If axial loads are applied, increase d_a and reduce D_a from the values listed above.
 (5) d_b (max.) are values for adjusting rings for NU, NJ Types.

SINGLE-ROW CYLINDRICAL ROLLER BEARINGS

Bore Diameter 40 – 55 mm

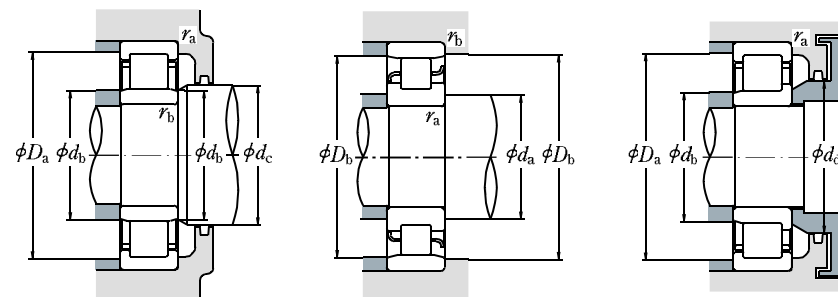
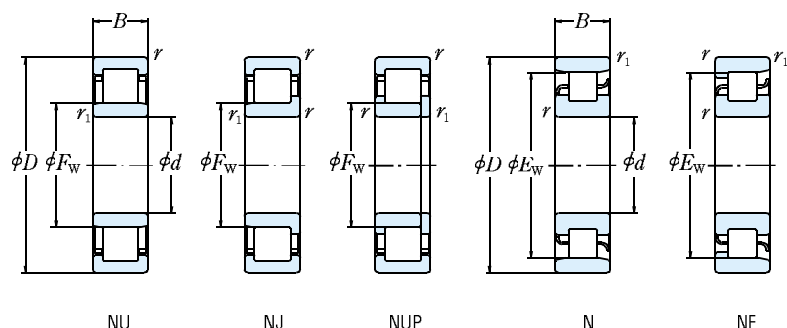

d	Boundary Dimensions (mm)						Basic Load Ratings (N)		Limiting Speeds ⁽¹⁾ (min ⁻¹)		
	D	B	r min.	r ₁ min.	F _W	E _W	C _r	C _{0r}	Grease	Oil	
40	68	15	1	0.6	47	61	27 300	29 000	10 000	12 000	
	80	18	1.1	1.1	—	70	43 500	43 000	8 500	10 000	
	80	18	1.1	1.1	49.5	—	55 500	55 500	7 500	9 000	
	80	23	1.1	1.1	49.5	—	72 500	77 500	7 500	9 000	
	90	23	1.5	1.5	—	77.5	58 500	57 000	6 700	8 500	
	90	23	1.5	1.5	52	—	83 000	81 500	6 700	8 000	
	90	33	1.5	1.5	52	—	114 000	122 000	6 000	7 500	
	110	27	2	2	58	92	95 500	89 000	6 000	7 500	
	45	75	16	1	0.6	52.5	67.5	32 500	35 500	9 000	11 000
		85	19	1.1	1.1	—	75	46 000	47 000	7 500	9 000
		85	19	1.1	1.1	54.5	—	63 000	66 500	6 700	8 000
85		23	1.1	1.1	54.5	—	76 000	84 500	6 700	8 500	
100		25	1.5	1.5	—	86.5	79 000	77 500	6 300	7 500	
100		25	1.5	1.5	58.5	—	97 500	98 500	6 000	7 500	
100		36	1.5	1.5	58.5	—	137 000	153 000	5 300	6 700	
120		29	2	2	64.5	100.5	107 000	102 000	5 600	6 700	
50		80	16	1	0.6	57.5	72.5	32 000	36 000	8 000	10 000
	90	20	1.1	1.1	—	80.4	48 000	51 000	7 100	8 500	
	90	20	1.1	1.1	59.5	—	69 000	76 500	6 300	7 500	
	90	23	1.1	1.1	59.5	—	83 500	97 000	6 300	8 000	
	110	27	2	2	—	95	87 000	86 000	5 600	6 700	
	110	27	2	2	65	—	110 000	113 000	5 000	6 000	
	110	40	2	2	65	—	163 000	187 000	5 000	6 300	
	130	31	2.1	2.1	—	110.8	139 000	136 000	5 000	6 000	
	130	31	2.1	2.1	70.8	110.8	129 000	124 000	5 000	6 000	
	55	90	18	1.1	1	64.5	80.5	37 500	44 000	7 500	9 000
		100	21	1.5	1.1	—	88.5	58 000	62 500	6 300	7 500
100		21	1.5	1.1	66	—	86 500	98 500	5 600	7 100	
100		25	1.5	1.1	66	—	101 000	122 000	5 600	7 100	
120		29	2	2	—	104.5	111 000	111 000	5 000	6 300	
120		29	2	2	70.5	—	137 000	143 000	4 500	5 600	
120		43	2	2	70.5	—	201 000	233 000	4 500	5 600	
140		33	2.1	2.1	77.2	117.2	139 000	138 000	4 500	5 600	

Bearing Numbers ⁽²⁾						Abutment and Fillet Dimensions (mm)										Mass (kg) approx.
NU NJ NUP N NF						d _a ⁽⁴⁾ min.	d _b min.	d _b ⁽⁵⁾ max.	d _c min.	d _a min.	D _a ⁽⁴⁾ max.	D _b max.	D _b min.	r _a max.	r _b max.	
NU1008	NU	NJ	NUP	N	—	45	44	46	49	—	63	64	62	1	0.6	
N 208	—	—	—	N	NF	46.5	—	—	—	—	—	73.5	72	1	1	
NU 208 EW	NU	NJ	NUP	—	—	46.5	46.5	48	52	56	73.5	—	—	1	1	
NU2208 ET	NU	NJ	NUP	—	—	46.5	46.5	48	52	56	73.5	—	—	1	1	
N 308	—	—	—	N	NF	48	—	—	—	—	—	82	79	1.5	1.5	
NU 308 EW	NU	NJ	NUP	—	—	48	48	50	55	60	82	—	—	1.5	1.5	
NU2308 ET	NU	NJ	NUP	—	—	48	48	50	55	60	82	—	—	1.5	1.5	
NU 408	NU	NJ	NUP	N	NF	49	49	56	60	67	101	101	94	2	2	
NU1009	NU	—	—	N	NF	50	49	51	54	—	70	71	68	1	0.6	
N 209	—	—	—	N	NF	51.5	—	—	—	—	—	78.5	77	1	1	
NU 209 EW	NU	NJ	NUP	—	—	51.5	51.5	52	57	61	78.5	—	—	1	1	
NU2209 ET	NU	NJ	NUP	—	—	51.5	51.5	52	57	61	78.5	—	—	1	1	
N 309	—	—	—	N	NF	53	—	—	—	—	—	92	77	1.5	1.5	
NU 309 EW	NU	NJ	NUP	—	—	53	53	56	60	66	92	—	—	1.5	1.5	
NU2309 ET	NU	NJ	NUP	—	—	53	53	56	60	66	92	—	—	1.5	1.5	
NU 409	NU	NJ	NUP	N	NF	54	54	62	66	74	111	111	103	2	2	
NU1010	NU	NJ	NUP	N	—	55	54	56	59	—	75	76	73	1	0.6	
N 210	—	—	—	N	NF	56.5	—	—	—	—	—	83.5	82	1	1	
NU 210 EW	NU	NJ	NUP	—	—	56.5	56.5	57	62	67	83.5	—	—	1	1	
NU2210 ET	NU	NJ	NUP	—	—	56.5	56.5	57	62	67	83.5	—	—	1	1	
N 310	—	—	—	N	NF	59	—	—	—	—	—	101	97	2	2	
NU 310 EW	NU	NJ	NUP	—	—	59	59	63	67	73	101	—	—	2	2	
NU2310 ET	NU	NJ	NUP	—	—	59	59	63	67	73	101	—	—	2	2	
N 410	—	—	—	N	NF	65	—	—	—	—	—	117	113	2	2	
NU 410	NU	NJ	NUP	N	NF	61	61	68	73	81	119	119	113.3	2	2	
NU1011	NU	NJ	—	N	—	61.5	60	63	66	—	83.5	85	82	1	1	
N 211	—	—	—	N	NF	63	—	—	—	—	—	93.5	91	1.5	1	
NU 211 EW	NU	NJ	NUP	—	—	63	61.5	64	68	73	92	—	—	1.5	1	
NU2211 ET	NU	NJ	NUP	—	—	63	61.5	64	68	73	92	—	—	1.5	1	
N 311	—	—	—	N	NF	64	—	—	—	—	—	111	107	2	2	
NU 311 EW	NU	NJ	NUP	—	—	64	64	68	72	80	111	—	—	2	2	
NU2311 ET	NU	NJ	NUP	—	—	64	64	68	72	80	111	—	—	2	2	
NU 411	NU	NJ	NUP	N	NF	66	66	75	79	87	129	129	119	2	2	

Notes (1) The limiting speeds listed above apply to bearings with machined cages (No suffix). For bearings with pressed cages, reduce the limiting speed by 20%. (Not applicable to bearing numbers with an EM, EW, or ET suffix.)
 (2) The bearings with suffix ET have polyamide cage. The maximum operating temperature should be less than 120°C.

Notes (3) When L-shaped thrust collars (See section for L-Shaped Thrust Collars starting on page B104) are used, the bearings become the NH type.
 (4) If axial loads are applied, increase d_a and reduce D_a from the values listed above.
 (5) d_b (max.) are values for adjusting rings for NU, NJ Types.

SINGLE-ROW CYLINDRICAL ROLLER BEARINGS

Bore Diameter 60 – 75 mm

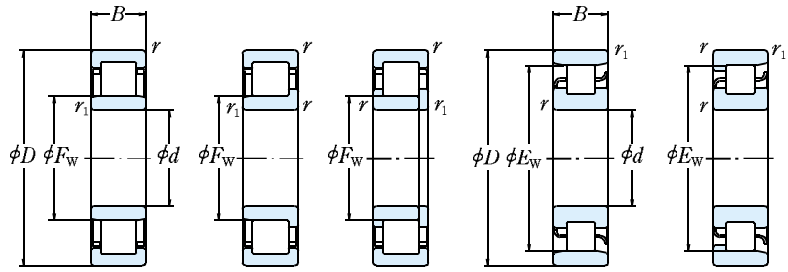

NU

NJ

NUP

N

NF

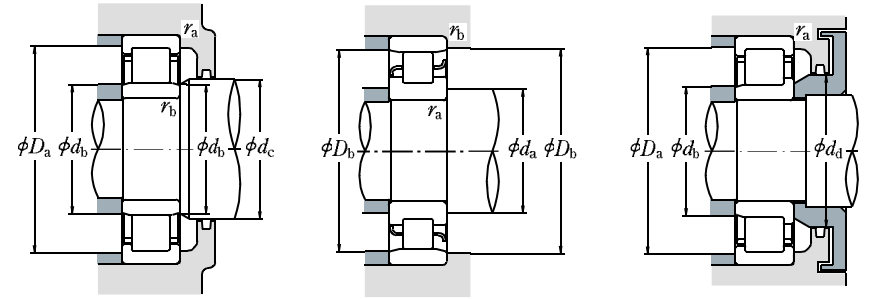

<i>d</i>	Boundary Dimensions (mm)						Basic Load Ratings (N)		Limiting Speeds ⁽¹⁾ (min ⁻¹)		
	<i>D</i>	<i>B</i>	<i>r</i> min.	<i>r</i> ₁ min.	<i>F_W</i>	<i>E_W</i>	<i>C_r</i>	<i>C_{0r}</i>	Grease	Oil	
60	95	18	1.1	1	69.5	85.5	40 000	48 500	6 700	8 500	
	110	22	1.5	1.5	—	97.5	68 500	75 000	6 000	7 100	
	110	22	1.5	1.5	72	—	97 500	107 000	5 300	6 300	
	110	28	1.5	1.5	72	—	131 000	157 000	5 300	6 300	
	130	31	2.1	2.1	—	113	124 000	126 000	4 800	5 600	
	130	31	2.1	2.1	77	—	124 000	126 000	4 800	5 600	
	130	31	2.1	2.1	77	—	150 000	157 000	4 800	5 600	
	130	46	2.1	2.1	77	—	222 000	262 000	4 300	5 300	
	150	35	2.1	2.1	83	127	167 000	168 000	4 300	5 300	
	65	100	18	1.1	1	74.5	90.5	41 000	51 000	6 300	8 000
		120	23	1.5	1.5	—	105.6	84 000	94 500	5 300	6 300
		120	23	1.5	1.5	78.5	—	108 000	119 000	4 800	5 600
120		31	1.5	1.5	78.5	—	149 000	181 000	4 800	6 000	
140		33	2.1	2.1	—	121.5	135 000	139 000	4 300	5 300	
140		33	2.1	2.1	83.5	—	135 000	139 000	4 300	5 300	
140		33	2.1	2.1	82.5	—	181 000	191 000	4 300	5 300	
140		48	2.1	2.1	82.5	—	233 000	265 000	3 800	4 800	
160		37	2.1	2.1	89.3	135.3	182 000	186 000	4 000	4 800	
70		110	20	1.1	1	80	100	58 500	70 500	6 000	7 100
		125	24	1.5	1.5	—	110.5	83 500	95 000	5 000	6 300
		125	24	1.5	1.5	83.5	—	119 000	137 000	5 000	6 300
		125	31	1.5	1.5	83.5	—	156 000	194 000	4 500	5 600
		150	35	2.1	2.1	—	130	149 000	156 000	4 000	5 000
	150	35	2.1	2.1	90	—	158 000	168 000	4 000	5 000	
	150	35	2.1	2.1	89	—	205 000	222 000	4 000	5 000	
	150	51	2.1	2.1	89	—	274 000	325 000	3 600	4 500	
	180	42	3	3	100	152	228 000	236 000	3 600	4 300	
	75	115	20	1.1	1	85	105	60 000	74 500	5 600	6 700
		130	25	1.5	1.5	—	116.5	96 500	111 000	4 800	6 000
130		25	1.5	1.5	88.5	—	130 000	156 000	4 800	6 000	
130		31	1.5	1.5	88.5	—	162 000	207 000	4 300	5 300	
160		37	2.1	2.1	—	139.5	179 000	189 000	3 800	4 800	
160		37	2.1	2.1	95.5	—	179 000	189 000	3 800	4 800	
160		37	2.1	2.1	95	—	240 000	263 000	3 800	4 800	
160		55	2.1	2.1	95	—	330 000	395 000	3 400	4 300	
190		45	3	3	104.5	160.5	262 000	274 000	3 400	4 000	

Bearing Numbers ⁽²⁾	Abutment and Fillet Dimensions (mm)										Mass (kg) approx.					
	NU	NJ	NUP	N	NF	<i>d</i> _a ⁽⁴⁾ min.	<i>d</i> _b min.	<i>d</i> _b ⁽⁵⁾ max.	<i>d</i> _c min.	<i>d</i> _a min.		<i>D</i> _a ⁽⁴⁾ max.	<i>D</i> _b max.	<i>D</i> _b min.	<i>r</i> _a max.	<i>r</i> _b max.
NU1012	NU	NJ	—	N	NF	66.5	65	68	71	—	88.5	90	87	1	1	0.474
N 212	—	—	—	N	NF	68	—	—	—	—	—	102	100	1.5	1.5	0.823
NU 212 EW	NU	NJ	NUP	—	—	68	68	70	75	80	102	—	—	1.5	1.5	0.824
NU2212 ET	NU	NJ	NUP	—	—	68	68	70	75	80	102	—	—	1.5	1.5	1.06
N 312	—	—	—	N	NF	71	—	—	—	—	—	119	115	2	2	1.78
NU 312	NU	NJ	NUP	—	—	71	71	75	79	86	119	—	—	2	2	1.82
NU 312 EM	NU	NJ	NUP	—	—	71	71	75	79	86	119	—	—	2	2	2.06
NU2312 ET	NU	NJ	NUP	—	—	71	71	75	79	86	119	—	—	2	2	2.7
NU 412	NU	NJ	NUP	N	NF	71	71	80	85	94	139	139	130	2	2	3.04
NU1013	NU	NJ	—	N	NF	71.5	70	73	76	—	93.5	95	92	1	1	0.504
N 312	—	—	—	N	NF	73	—	—	—	—	—	112	108	1.5	1.5	1.05
NU 213 EW	NU	NJ	NUP	—	—	73	73	76	81	87	112	—	—	1.5	1.5	1.05
NU2213 ET	NU	NJ	NUP	—	—	73	73	76	81	87	112	—	—	1.5	1.5	1.41
N 313	—	—	—	N	NF	76	—	—	—	—	—	129	125	2	2	2.17
NU 313	NU	NJ	NUP	—	—	76	76	81	85	93	129	—	—	2	2	2.23
NU 313 EM	NU	NJ	NUP	—	—	76	76	80	85	93	129	—	—	2	2	2.56
NU2313 ET	NU	NJ	NUP	—	—	76	76	80	85	93	129	—	—	2	2	3.16
NU 413	NU	NJ	—	N	NF	76	76	86	91	100	149	149	138.8	2	2	3.63
NU1014	NU	NJ	NUP	N	NF	76.5	75	79	82	—	103.5	105	101	1	1	0.693
N 214	—	—	—	N	NF	78	—	—	—	—	—	117	113	1.5	1.5	1.14
NU 214 EM	NU	NJ	NUP	—	—	78	78	81	86	92	117	—	—	1.5	1.5	1.29
NU2214 ET	NU	NJ	NUP	—	—	78	78	81	86	92	117	—	—	1.5	1.5	1.49
N 314	—	—	—	N	NF	81	—	—	—	—	—	139	133.5	2	2	2.67
NU 314	NU	NJ	NUP	—	—	81	81	87	92	100	139	—	—	2	2	2.75
NU 314 EM	NU	NJ	NUP	—	—	81	81	86	92	100	139	—	—	2	2	3.09
NU2314 ET	NU	NJ	NUP	—	—	81	81	86	92	100	139	—	—	2	2	3.92
NU 414	NU	NJ	NUP	N	NF	83	83	97	102	112	167	167	155	2.5	2.5	5.28
NU1015	NU	—	—	N	NF	81.5	80	83	87	—	108.5	110	106	1	1	0.731
N 215	—	—	—	N	NF	83	—	—	—	—	—	122	119	1.5	1.5	1.23
NU 215 EM	NU	NJ	NUP	—	—	83	83	86	90	96	122	—	—	1.5	1.5	1.44
NU2215 ET	NU	NJ	NUP	—	—	83	83	86	90	96	122	—	—	1.5	1.5	1.57
N 315	—	—	—	N	NF	86	—	—	—	—	—	149	143	2	2	3.2
NU 315	NU	NJ	NUP	—	—	86	86	93	97	106	149	—	—	2	2	3.26
NU 315 EM	NU	NJ	NUP	—	—	86	86	92	97	106	149	—	—	2	2	3.73
NU2315 ET	NU	NJ	NUP	—	—	86	86	92	97	106	149	—	—	2	2	4.86
NU 415	NU	NJ	—	N	NF	88	88	102	107	118	177	177	164	2.5	2.5	6.27

Notes (1) The limiting speeds listed above apply to bearings with machined cages (No suffix). For bearings with pressed cages, reduce the limiting speed by 20%. (Not applicable to bearing numbers with an EM, EW, or ET suffix.)
 (2) The bearings with suffix ET have polyamide cage. The maximum operating temperature should be less than 120°C.

Notes (3) When L-shaped thrust collars (See section for L-Shaped Thrust Collars starting on page B104) are used, the bearings become the NH type.
 (4) If axial loads are applied, increase *d*_a and reduce *D*_a from the values listed above.
 (5) *d*_b (max.) are values for adjusting rings for NU, NJ Types.

SINGLE-ROW CYLINDRICAL ROLLER BEARINGS

Bore Diameter 80 – 95 mm

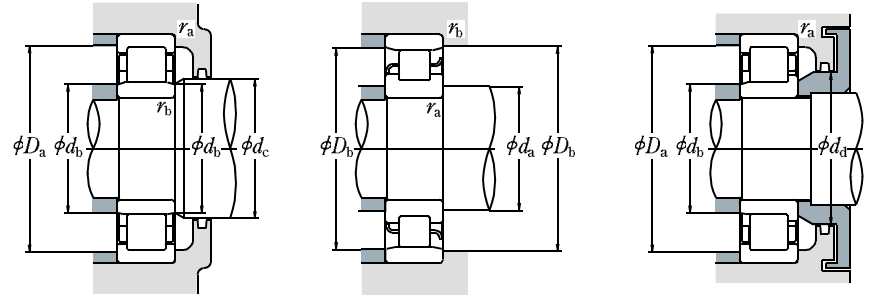
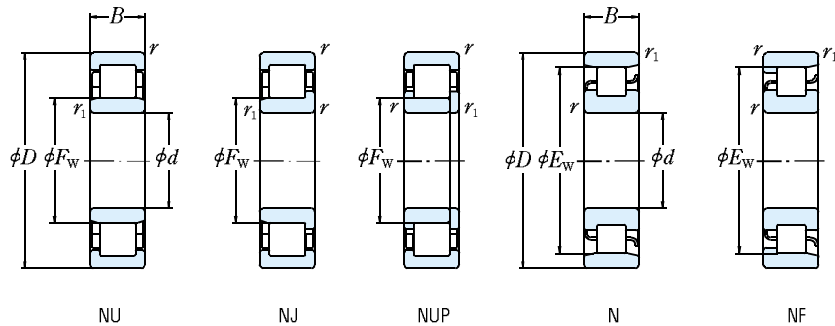

d	Boundary Dimensions (mm)						Basic Load Ratings (N)		Limiting Speeds ⁽¹⁾ (min ⁻¹)		
	D	B	r min.	r ₁ min.	F _w	E _w	C _r	C _{0r}	Grease	Oil	
80	125	22	1.1	1	91.5	113.5	72 500	90 500	5 300	6 300	
	140	26	2	2	—	125.3	106 000	122 000	4 500	5 300	
	140	26	2	2	95.3	—	139 000	167 000	4 500	5 300	
	140	33	2	2	95.3	—	186 000	243 000	4 000	5 000	
	170	39	2.1	2.1	—	147	190 000	207 000	3 600	4 300	
	170	39	2.1	2.1	101	—	256 000	282 000	3 600	4 300	
	170	58	2.1	2.1	101	—	355 000	430 000	3 200	4 000	
	200	48	3	3	110	170	299 000	315 000	3 200	3 800	
	85	130	22	1.1	1	96.5	118.5	74 500	95 500	5 000	6 000
		150	28	2	2	—	133.8	120 000	140 000	4 300	5 000
150		28	2	2	100.5	—	167 000	199 000	4 300	5 000	
150		36	2	2	100.5	—	217 000	279 000	3 800	4 500	
180		41	3	3	—	156	225 000	247 000	3 400	4 000	
180		41	3	3	108	—	212 000	228 000	3 400	4 000	
180		41	3	3	108	—	291 000	330 000	3 400	4 000	
180		60	3	3	108	—	395 000	485 000	3 000	3 800	
210		52	4	4	113	177	335 000	350 000	3 000	3 800	
90		140	24	1.5	1.1	103	127	88 000	114 000	4 500	5 600
	160	30	2	2	—	143	152 000	178 000	4 000	4 800	
	160	30	2	2	107	—	182 000	217 000	4 000	4 800	
	160	40	2	2	107	—	242 000	315 000	3 600	4 300	
	190	43	3	3	—	165	240 000	265 000	3 200	3 800	
	190	43	3	3	115	—	240 000	265 000	3 200	3 800	
	190	43	3	3	113.5	—	315 000	355 000	3 200	3 800	
	190	64	3	3	113.5	—	435 000	535 000	2 800	3 400	
	225	54	4	4	123.5	191.5	375 000	400 000	2 800	3 400	
	95	145	24	1.5	1.1	108	132	90 500	120 000	4 300	5 300
170		32	2.1	2.1	—	151.5	166 000	196 000	3 800	4 500	
170		32	2.1	2.1	112.5	—	220 000	265 000	3 800	4 500	
170		43	2.1	2.1	112.5	—	286 000	370 000	3 400	4 000	
200		45	3	3	—	173.5	259 000	289 000	3 000	3 600	
200		45	3	3	121.5	—	259 000	289 000	3 000	3 600	
200		45	3	3	121.5	—	335 000	385 000	3 000	3 600	
200		67	3	3	121.5	—	460 000	585 000	2 600	3 400	
240		55	4	4	133.5	201.5	400 000	445 000	2 600	3 200	

Bearing Numbers ⁽²⁾						Abutment and Fillet Dimensions (mm)										Mass (kg) approx.
NU NJ NUP N NF						d _a ⁽⁴⁾ min.	d _b min.	d _b ⁽⁵⁾ max.	d _c min.	d _a min.	D _a ⁽⁴⁾ max.	D _b max.	D _b min.	r _a max.	r _b max.	
NU1016	NU	—	NUP	N	—	86.5	85	90	94	—	118.5	120	115	1	1	0.969
N 216	—	—	—	N NF	—	89	—	—	—	—	—	131	128	2	2	1.47
NU 216 EM	NU	NJ	NUP	—	—	89	89	92	97	104	131	—	—	2	2	1.7
NU2216 ET	NU	NJ	NUP	—	—	89	89	92	97	104	131	—	—	2	2	1.96
N 316	—	—	—	N NF	—	91	—	—	—	—	—	159	150	2	2	3.85
NU 316 EM	NU	NJ	NUP	—	—	91	91	98	105	114	159	—	—	2	2	4.45
NU2316 ET	NU	NJ	NUP	—	—	91	91	98	105	114	159	—	—	2	2	5.73
NU 416	NU	NJ	—	N NF	—	93	93	107	112	124	187	187	173	2.5	2.5	7.36
NU1017	NU	—	—	N	—	91.5	90	95	99	—	123.5	125	120	1	1	1.01
N 217	—	—	—	N NF	—	94	—	—	—	—	—	141	137	2	2	1.87
NU 217 EM	NU	NJ	NUP	—	—	94	94	98	104	110	141	—	—	2	2	2.11
NU2217 ET	NU	NJ	NUP	—	—	94	94	98	104	110	141	—	—	2	2	2.44
N 317	—	—	—	N NF	—	98	—	—	—	—	—	167	159	2.5	2.5	4.53
NU 317	NU	NJ	NUP	—	—	98	98	105	110	119	167	—	—	2.5	2.5	4.6
NU 317 EM	NU	NJ	NUP	—	—	98	98	105	110	119	167	—	—	2.5	2.5	5.26
NU2317 ET	NU	NJ	NUP	—	—	98	98	105	110	119	167	—	—	2.5	2.5	6.77
NU 417	NU	NJ	—	N NF	—	101	101	110	115	128	194	194	180	3	3	9.56
NU1018	NU	—	NUP	N	—	98	96.5	101	106	—	132	133.5	129	1.5	1	1.35
N 218	—	—	—	N NF	—	99	—	—	—	—	—	151	146	2	2	2.31
NU 218 EM	NU	NJ	NUP	—	—	99	99	104	109	116	151	—	—	2	2	2.6
NU2218 ET	NU	NJ	NUP	—	—	99	99	104	109	116	151	—	—	2	2	3.11
N 318	—	—	—	N NF	—	103	—	—	—	—	—	177	168	2.5	2.5	5.31
NU 318	NU	NJ	NUP	—	—	103	103	112	117	127	177	—	—	2.5	2.5	5.38
NU 318 EM	NU	NJ	NUP	—	—	103	103	111	117	127	177	—	—	2.5	2.5	6.1
NU2318 ET	NU	NJ	NUP	—	—	103	103	111	117	127	177	—	—	2.5	2.5	7.9
NU 418	NU	NJ	—	N NF	—	106	106	120	125	139	209	209	196	3	3	11.5
NU1019	NU	NJ	—	N	—	103	101.5	106	111	—	137	138.5	134	1.5	1	1.41
N 219	—	—	—	N NF	—	106	—	—	—	—	—	159	155	2	2	2.79
NU 219 EM	NU	NJ	NUP	—	—	106	106	110	116	123	159	—	—	2	2	3.17
NU2219 ET	NU	NJ	NUP	—	—	106	106	110	116	123	159	—	—	2	2	3.81
N 319	—	—	—	N NF	—	108	—	—	—	—	—	187	177	2.5	2.5	6.09
NU 319	NU	NJ	NUP	—	—	108	108	118	124	134	187	—	—	2.5	2.5	6.23
NU 319 EM	NU	NJ	NUP	—	—	108	108	118	124	134	187	—	—	2.5	2.5	7.13
NU2319 ET	NU	NJ	NUP	—	—	108	108	118	124	134	187	—	—	2.5	2.5	9.21
NU 419	NU	NJ	NUP	—	NF	111	111	130	136	149	224	224	206	3	3	13.6

Notes ⁽¹⁾ The limiting speeds listed above apply to bearings with machined cages (No suffix). For bearings with pressed cages, reduce the limiting speed by 20%. (Not applicable to bearing numbers with an EM, EW, or ET suffix.)
⁽²⁾ The bearings with suffix ET have polyamide cage. The maximum operating temperature should be less than 120°C.

Notes ⁽³⁾ When L-shaped thrust collars (See section for L-Shaped Thrust Collars starting on page B104) are used, the bearings become the NH type.
⁽⁴⁾ If axial loads are applied, increase d_a and reduce D_a from the values listed above.
⁽⁵⁾ d_b (max.) are values for adjusting rings for NU, NJ Types.

SINGLE-ROW CYLINDRICAL ROLLER BEARINGS

Bore Diameter 100 – 120 mm

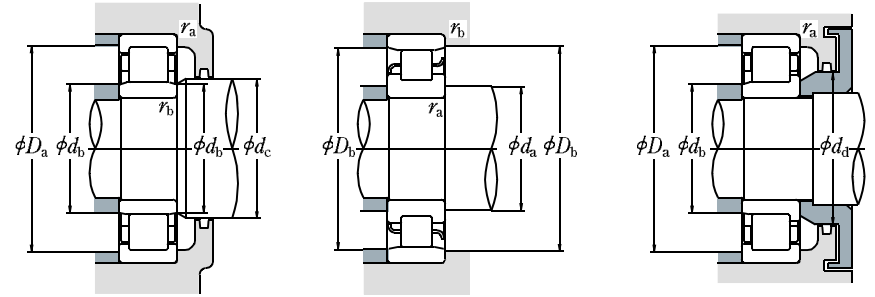
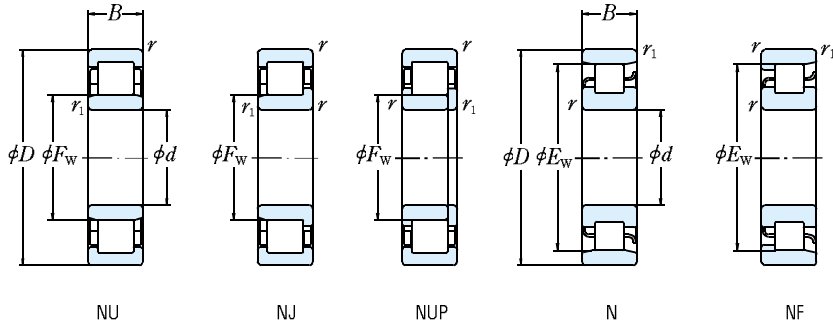

<i>d</i>	Boundary Dimensions (mm)						Basic Load Ratings (N)		Limiting Speeds ⁽¹⁾ (min ⁻¹)		
	<i>D</i>	<i>B</i>	<i>r</i> min.	<i>r</i> ₁ min.	<i>F</i> _W	<i>E</i> _W	<i>C</i> _r	<i>C</i> _{0r}	Grease	Oil	
100	150	24	1.5	1.1	113	137	93 000	126 000	4 300	5 300	
	180	34	2.1	2.1	—	160	183 000	217 000	3 600	4 300	
	180	34	2.1	2.1	119	—	249 000	305 000	3 600	4 300	
	180	46	2.1	2.1	119	—	335 000	445 000	3 200	3 800	
	215	47	3	3	—	185.5	299 000	335 000	2 800	3 400	
	215	47	3	3	129.5	—	299 000	335 000	2 800	3 400	
	215	47	3	3	127.5	—	380 000	425 000	2 800	3 400	
	215	73	3	3	127.5	—	570 000	715 000	2 400	3 000	
	250	58	4	4	139	211	450 000	500 000	2 600	3 000	
	105	160	26	2	1.1	119.5	145.5	109 000	149 000	4 000	4 800
		190	36	2.1	2.1	—	168.8	201 000	241 000	3 400	4 000
190		36	2.1	2.1	125	—	262 000	310 000	3 400	4 000	
225		49	3	3	—	195	340 000	390 000	2 600	3 200	
225		49	3	3	133	—	425 000	480 000	2 600	3 200	
260		60	4	4	144.5	220.5	495 000	555 000	2 400	3 000	
110	170	28	2	1.1	125	155	131 000	174 000	3 800	4 500	
	200	38	2.1	2.1	—	178.5	229 000	272 000	3 200	3 800	
	200	38	2.1	2.1	132.5	—	293 000	365 000	3 200	3 800	
	200	53	2.1	2.1	132.5	—	385 000	515 000	2 800	3 400	
	240	50	3	3	—	207	380 000	435 000	2 600	3 000	
	240	50	3	3	143	—	450 000	525 000	2 600	3 000	
	280	65	4	4	155	—	550 000	620 000	2 200	2 800	
120	180	28	2	1.1	135	165	139 000	191 000	3 400	4 300	
	215	40	2.1	2.1	—	191.5	260 000	320 000	3 000	3 400	
	215	40	2.1	2.1	143.5	—	335 000	420 000	3 000	3 400	
	215	58	2.1	2.1	143.5	—	450 000	620 000	2 600	3 200	
	260	55	3	3	—	226	450 000	510 000	2 200	2 800	
	260	55	3	3	154	—	530 000	610 000	2 200	2 800	
	260	86	3	3	154	—	795 000	1 030 000	2 000	2 600	
	310	72	5	5	170	260	675 000	770 000	2 000	2 400	

Bearing Numbers ⁽²⁾	Abutment and Fillet Dimensions (mm)											Mass (kg) approx.				
	NU ⁽³⁾	NJ	NUP	N	NF	<i>d</i> _a ⁽⁴⁾ min.	<i>d</i> _b min.	<i>d</i> _b ⁽⁵⁾ max.	<i>d</i> _c min.	<i>d</i> _a min.	<i>D</i> _a ⁽⁴⁾ max.		<i>D</i> _b max.	<i>D</i> _b min.	<i>r</i> _a max.	<i>r</i> _b max.
NU1020	NU	NJ	NUP	N	NF	108	106.5	111	116	—	142	143.5	139	1.5	1	1.47
N 220	—	—	—	N	NF	111	—	—	—	—	—	169	163	2	2	3.36
NU 220 EM	NU	NJ	NUP	—	—	111	111	116	122	130	169	—	—	2	2	3.81
NU2220 ET	NU	NJ	NUP	—	—	111	111	116	122	130	169	—	—	2	2	4.69
N 320	—	—	—	N	NF	113	—	—	—	—	—	202	190	2.5	2.5	7.59
NU 320	NU	NJ	NUP	—	—	113	113	126	132	143	202	—	—	2.5	2.5	7.69
NU 320 EM	NU	NJ	NUP	—	—	113	113	124	132	143	202	—	—	2.5	2.5	8.63
NU2320 ET	NU	NJ	NUP	—	—	113	113	124	132	143	202	—	—	2.5	2.5	11.8
NU 420	NU	NJ	—	N	NF	116	116	135	141	156	234	234	215	3	3	15.5
NU1021	NU	—	—	N	NF	114	111.5	118	122	—	151	153.5	147	2	1	1.83
N 221	—	—	—	N	NF	116	—	—	—	—	—	179	172	2	2	4.0
NU 221 EM	NU	NJ	NUP	—	—	116	116	121	129	137	179	—	—	2	2	4.58
N 321	—	—	—	N	NF	118	—	—	—	—	—	212	199	2.5	2.5	8.69
NU 321 EM	NU	NJ	NUP	—	—	118	118	131	137	149	212	—	—	2.5	2.5	9.84
NU 421	NU	NJ	—	N	NF	121	121	141	147	162	244	244	225	3	3	17.3
NU1022	NU	NJ	—	N	NF	119	116.5	123	128	—	161	163.5	157	2	1	2.27
N 222	—	—	—	N	NF	121	—	—	—	—	—	189	182	2	2	4.64
NU 222 EM	NU	NJ	NUP	—	—	121	121	129	135	144	189	—	—	2	2	5.37
NU2222 EM	NU	NJ	NUP	—	—	121	121	129	135	144	189	—	—	2	2	7.65
N 322	—	—	—	N	NF	123	—	—	—	—	—	227	211	2.5	2.5	10.3
NU 322 EM	NU	NJ	NUP	—	—	123	123	139	145	158	227	—	—	2.5	2.5	11.8
NU 422	NU	NJ	—	—	—	126	126	151	157	173	264	—	—	3	3	22.1
NU1024	NU	NJ	NUP	N	—	129	126.5	133	138	—	171	173.5	167	2	1	2.43
N 224	—	—	—	N	NF	131	—	—	—	—	—	204	196	2	2	5.63
NU 224 EM	NU	NJ	NUP	—	—	131	131	140	146	156	204	—	—	2	2	6.43
NU2224 EM	NU	NJ	NUP	—	—	131	131	140	146	156	204	—	—	2	2	9.51
N 324	—	—	—	N	NF	133	—	—	—	—	—	247	230	2.5	2.5	12.9
NU 324 EM	NU	NJ	NUP	—	—	133	133	150	156	171	247	—	—	2.5	2.5	15
NU2324 EM	NU	NJ	NUP	—	—	133	133	150	156	171	247	—	—	2.5	2.5	25
NU 424	NU	NJ	NUP	N	—	140	140	166	172	190	290	290	266	4	4	30.2

- Notes** (1) The limiting speeds listed above apply to bearings with machined cages (No suffix). For bearings with pressed cages, reduce the limiting speed by 20%. (Not applicable to bearing numbers with an EM, EW, or ET suffix.)
 (2) The bearings with suffix ET have polyamide cage. The maximum operating temperature should be less than 120°C.

- Notes** (3) When L-shaped thrust collars (See section for L-Shaped Thrust Collars starting on page B104) are used, the bearings become the NH type.
 (4) If axial loads are applied, increase *d*_a and reduce *D*_a from the values listed above.
 (5) *d*_b (max.) are values for adjusting rings for NU, NJ Types.

SINGLE-ROW CYLINDRICAL ROLLER BEARINGS

Bore Diameter 130 – 160 mm

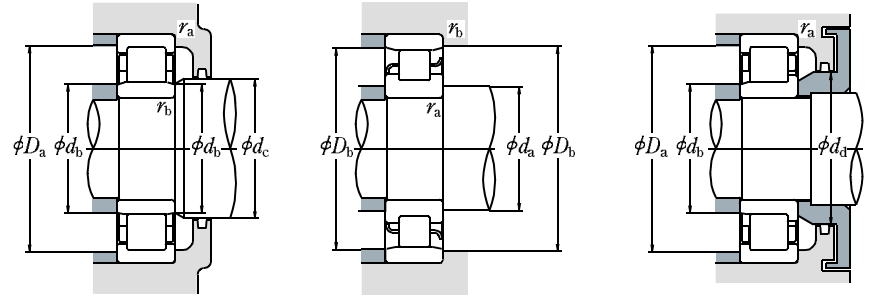
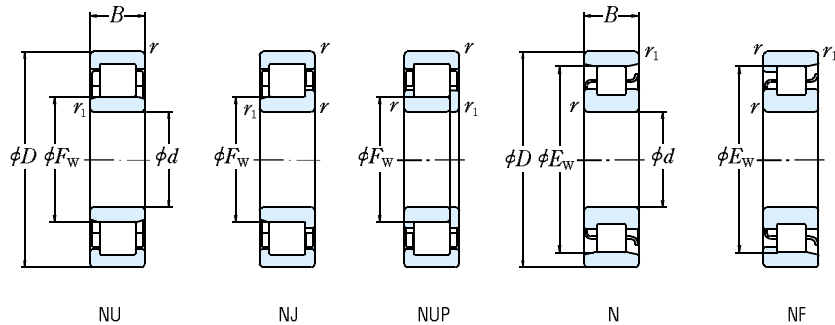

d	Boundary Dimensions (mm)						Basic Load Ratings (N)		Limiting Speeds ⁽¹⁾ (min ⁻¹)		
	D	B	r min.	r ₁ min.	F _W	E _W	C _r	C _{0r}	Grease	Oil	
130	200	33	2	1.1	148	182	172 000	238 000	3 200	3 800	
	230	40	3	3	—	204	270 000	340 000	2 600	3 200	
	230	40	3	3	153.5	—	365 000	455 000	2 600	3 200	
	230	64	3	3	153.5	—	530 000	735 000	2 400	3 000	
	280	58	4	4	—	243	500 000	570 000	2 200	2 600	
	280	58	4	4	167	—	615 000	735 000	2 200	2 600	
	280	93	4	4	167	—	920 000	1 230 000	1 900	2 400	
	340	78	5	5	185	285	825 000	955 000	1 800	2 200	
	140	210	33	2	1.1	158	192	176 000	250 000	3 000	3 600
		250	42	3	3	—	221	297 000	375 000	2 400	3 000
250		42	3	3	169	—	395 000	515 000	2 400	3 000	
250		68	3	3	169	—	550 000	790 000	2 200	2 800	
300		62	4	4	—	260	550 000	640 000	2 000	2 400	
300		62	4	4	180	—	665 000	795 000	2 000	2 400	
300		102	4	4	180	—	1 020 000	1 380 000	1 700	2 200	
360		82	5	5	198	302	875 000	1 020 000	1 700	2 000	
150		225	35	2.1	1.5	169.5	205.5	202 000	294 000	2 800	3 400
		270	45	3	3	—	238	360 000	465 000	2 200	2 800
	270	45	3	3	182	—	450 000	595 000	2 200	2 800	
	270	73	3	3	182	—	635 000	930 000	2 000	2 600	
	320	65	4	4	—	277	665 000	805 000	1 800	2 200	
	320	65	4	4	193	—	760 000	920 000	1 800	2 200	
	320	108	4	4	193	—	1 160 000	1 600 000	1 600	2 000	
	380	85	5	5	213	—	930 000	1 120 000	1 600	2 000	
	160	240	38	2.1	1.5	180	220	238 000	340 000	2 600	3 200
		290	48	3	3	—	255	430 000	570 000	2 200	2 600
290		48	3	3	195	—	500 000	665 000	2 200	2 600	
290		80	3	3	193	—	810 000	1 190 000	1 900	2 400	
340		68	4	4	—	292	700 000	875 000	1 700	2 000	
340		68	4	4	204	—	860 000	1 050 000	1 700	2 000	
340		114	4	4	204	—	1 310 000	1 820 000	1 500	1 900	

Bearing Numbers ⁽²⁾	Abutment and Fillet Dimensions (mm)											Mass (kg)				
	NU ⁽³⁾ NJ NUP N NF					d _a ⁽⁴⁾ min.	d _b min.	d _b ⁽⁵⁾ max.	d _c min.	d _a min.	D _a ⁽⁴⁾ max.		D _b max.	D _b min.	r _a max.	r _b max.
NU1026	NU	NJ	—	N	NF	139	136.5	146	151	—	191	193.5	184	2	1	3.66
N 226	—	—	—	N	NF	143	—	—	—	—	—	217	208	2.5	2.5	6.48
NU 226 EM	NU	NJ	NUP	—	—	143	143	150	158	168	217	—	—	2.5	2.5	8.03
NU2226 EM	NU	NJ	NUP	—	—	143	143	150	158	168	217	—	—	2.5	2.5	9.44
N 326	—	—	—	N	NF	146	—	—	—	—	—	264	247.5	3	3	17.7
NU326EM	NU	NJ	NUP	—	—	146	146	163	169	184	264	—	—	3	3	18.7
NU2326EM	NU	NJ	NUP	—	—	146	146	163	169	184	264	—	—	3	3	30
NU 426	NU	NJ	—	—	NF	150	150	180	187	208	320	320	291	4	4	39.6
NU1028	NU	NJ	NUP	N	—	149	146.5	156	161	—	201	203.5	194	2	1	3.87
N 228	—	—	—	N	NF	153	—	—	—	—	—	237	225	2.5	2.5	8.08
NU228EM	NU	NJ	NUP	—	—	153	153	165	171	182	237	—	—	2.5	2.5	9.38
NU2228EM	NU	NJ	NUP	—	—	153	153	165	171	182	237	—	—	2.5	2.5	15.2
N 328	—	—	—	N	NF	156	—	—	—	—	—	284	266	3	3	21.7
NU328EM	NU	NJ	NUP	—	—	156	156	176	182	198	284	—	—	3	3	22.8
NU2328EM	NU	NJ	NUP	—	—	156	156	176	182	198	284	—	—	3	3	37.7
NU 428	NU	NJ	—	N	—	160	160	193	200	222	340	340	308	4	4	46.4
NU1030	NU	NJ	—	N	NF	161	158	167	173	—	214	217	208	2	1.5	4.77
N 320	—	—	—	N	NF	163	—	—	—	—	—	257	242	2.5	2.5	10.4
NU230EM	NU	NJ	NUP	—	—	163	163	177	184	196	257	—	—	2.5	2.5	11.9
NU2230EM	NU	NJ	NUP	—	—	163	163	177	184	196	257	—	—	2.5	2.5	19.3
N 330	—	—	—	N	NF	166	—	—	—	—	—	304	283	3	3	25.8
NU330EM	NU	NJ	NUP	—	—	166	166	188	195	213	304	—	—	3	3	27.1
NU2330EM	NU	NJ	NUP	—	—	166	166	188	195	213	304	—	—	3	3	45.1
NU 430	NU	NJ	—	—	—	170	170	208	216	237	360	—	—	4	4	55.8
NU1032	NU	NJ	—	N	NF	171	168	178	184	—	229	232	222	2	1.5	5.81
N 332	—	—	—	N	NF	173	—	—	—	—	—	277	261	2.5	2.5	14.1
NU232EM	NU	NJ	NUP	—	—	173	173	190	197	210	277	—	—	2.5	2.5	14.7
NU2232EM	NU	NJ	NUP	—	—	173	173	188	197	210	277	—	—	2.5	2.5	24.5
N 332	—	—	—	N	—	176	—	—	—	—	—	324	298	3	3	30.8
NU332EM	NU	NJ	NUP	—	—	176	176	199	211	228	324	—	—	3	3	32.1
NU2332EM	NU	NJ	NUP	—	—	176	176	199	211	228	324	—	—	3	3	53.9

Notes (1) The limiting speeds listed above apply to bearings with machined cages (No suffix). For bearings with pressed cages, reduce the limiting speed by 20%. (Not applicable to bearing numbers with an EM, EW, or ET suffix.)
 (2) The bearings with suffix ET have polyamide cage. The maximum operating temperature should be less than 120°C.

Notes (3) When L-shaped thrust collars (See section for L-Shaped Thrust Collars starting on page B104) are used, the bearings become the NH type.
 (4) If axial loads are applied, increase d_a and reduce D_a from the values listed above.
 (5) d_b (max.) are values for adjusting rings for NU, NJ Types.

SINGLE-ROW CYLINDRICAL ROLLER BEARINGS

Bore Diameter 170 – 220 mm

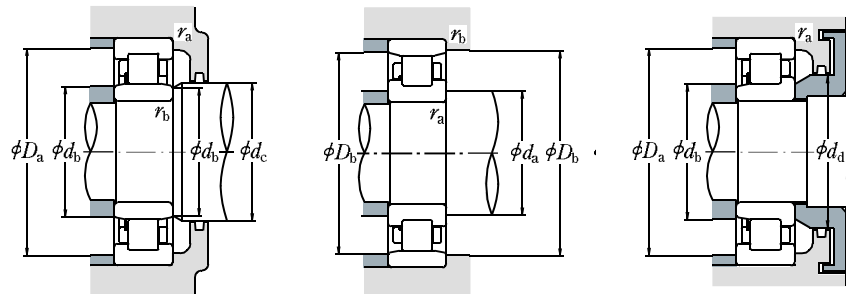
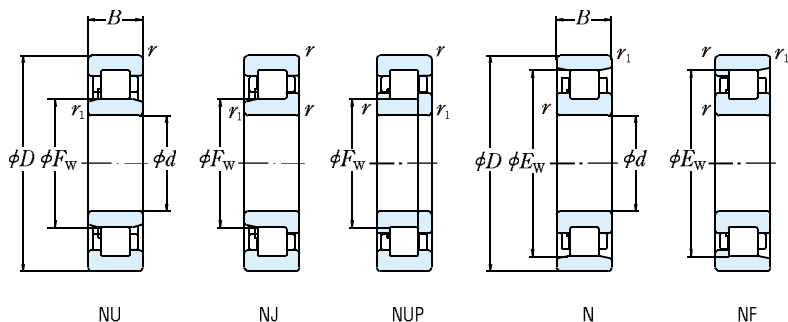

d	Boundary Dimensions (mm)						Basic Load Ratings (N)		Limiting Speeds (min ⁻¹)	
	D	B	r min.	r ₁ min.	F _W	E _W	C _r	C _{0r}	Grease	Oil
170	260	42	2.1	2.1	193	237	287 000	415 000	2 400	2 800
	310	52	4	4	—	272	475 000	635 000	2 000	2 400
	310	52	4	4	207	—	605 000	800 000	2 000	2 400
	310	86	4	4	205	—	925 000	1 330 000	1 800	2 200
	360	72	4	4	—	310	795 000	1 010 000	1 600	2 000
	360	72	4	4	218	—	930 000	1 150 000	1 600	2 000
180	360	120	4	4	216	—	1 490 000	2 070 000	1 400	1 800
	280	46	2.1	2.1	205	255	355 000	510 000	2 200	2 600
	320	52	4	4	—	282	495 000	675 000	1 900	2 200
	320	52	4	4	217	—	625 000	850 000	1 900	2 200
	320	86	4	4	215	—	1 010 000	1 510 000	1 700	2 000
	380	75	4	4	—	328	905 000	1 150 000	1 500	1 800
190	380	75	4	4	231	—	985 000	1 230 000	1 500	1 800
	380	126	4	4	227	—	1 560 000	2 220 000	1 300	1 700
	290	46	2.1	2.1	215	265	365 000	535 000	2 000	2 600
	340	55	4	4	—	299	555 000	770 000	1 800	2 200
	340	55	4	4	230	—	695 000	955 000	1 800	2 200
	340	92	4	4	228	—	1 100 000	1 670 000	1 600	2 000
200	400	78	5	5	—	345	975 000	1 260 000	1 400	1 700
	400	78	5	5	245	—	1 060 000	1 340 000	1 400	1 700
	400	132	5	5	240	—	1 770 000	2 520 000	1 300	1 600
	310	51	2.1	2.1	229	281	390 000	580 000	2 000	2 400
	360	58	4	4	—	316	620 000	865 000	1 700	2 000
	360	58	4	4	243	—	765 000	1 060 000	1 700	2 000
220	360	98	4	4	241	—	1 220 000	1 870 000	1 500	1 800
	420	80	5	5	—	360	975 000	1 270 000	1 300	1 600
	420	80	5	5	258	—	1 140 000	1 450 000	1 300	1 600
	420	138	5	5	253	—	1 910 000	2 760 000	1 200	1 500
	340	56	3	3	250	310	500 000	750 000	1 800	2 200
	400	65	4	4	—	350	760 000	1 080 000	1 500	1 800
400	400	65	4	4	270	—	760 000	1 080 000	1 500	1 800
	400	108	4	4	270	—	1 140 000	1 810 000	1 300	1 600
	460	88	5	5	—	396	1 190 000	1 570 000	1 200	1 500
	460	88	5	5	284	—	1 190 000	1 570 000	1 200	1 500

Bearing Numbers						Abutment and Fillet Dimensions (mm)										Mass (kg)
						d _a (²) min.	d _b min.	d _b (³) max.	d _c min.	d _a min.	D _a (²) max.	D _b max.	D _b min.	r _a max.	r _b max.	approx.
NU1034	NU	NJ	—	N	—	181	181	190	197	—	249	249	239	2	2	7.91
N 234	—	—	—	N	NF	186	—	—	—	—	294	294	278	3	3	17.4
NU234EM	NU	NJ	NUP	—	—	186	186	202	211	223	294	—	—	3	3	18.3
NU2234EM	NU	NJ	NUP	—	—	186	186	200	211	223	294	—	—	3	3	29.9
N 334	—	—	—	N	—	186	—	—	—	—	344	—	—	3	3	36.6
NU334EM	NU	NJ	NUP	—	—	186	186	213	223	241	344	—	—	3	3	37.9
NU2334EM	NU	NJ	NUP	—	—	186	186	210	223	241	344	—	—	3	3	63.4
NU1036	NU	NJ	—	N	NF	191	191	202	209	—	269	269	258	2	2	10.2
N 236	—	—	—	N	NF	196	—	—	—	—	304	—	—	3	3	18.1
NU326EM	NU	NJ	NUP	—	—	196	196	212	221	233	304	—	—	3	3	19
NU2236EM	NU	NJ	NUP	—	—	196	196	210	221	233	304	—	—	3	3	31.4
N 336	—	—	—	N	NF	196	—	—	—	—	364	—	—	3	3	42.6
NU336EM	NU	NJ	NUP	—	—	196	196	226	235	255	364	—	—	3	3	44
NU2336EM	NU	NJ	NUP	—	—	196	196	222	235	255	364	—	—	3	3	74.6
NU1038	NU	NJ	—	N	—	201	201	212	219	—	279	279	268	2	2	10.7
N 238	—	—	—	N	NF	206	—	—	—	—	324	—	—	3	3	22
NU238EM	NU	NJ	NUP	—	—	206	206	225	234	247	324	—	—	3	3	23
NU2238EM	NU	NJ	NUP	—	—	206	206	223	234	247	324	—	—	3	3	38.3
N 338	—	—	—	N	—	210	—	—	—	—	380	—	—	4	4	48.7
NU338EM	NU	NJ	NUP	—	—	210	210	240	248	268	380	—	—	4	4	50.6
NU2338EM	NU	NJ	NUP	—	—	210	210	235	248	268	380	—	—	4	4	86.2
NU1040	NU	NJ	—	N	NF	211	211	226	233	—	299	299	284	2	2	14
N 240	—	—	—	N	NF	216	—	—	—	—	344	—	—	3	3	26.2
NU240EM	NU	NJ	NUP	—	—	216	216	238	247	261	344	—	—	3	3	27.4
NU2240EM	NU	NJ	NUP	—	—	216	216	235	247	261	344	—	—	3	3	46.1
N 340	—	—	—	N	NF	220	—	—	—	—	400	—	—	4	4	55.3
NU340EM	NU	NJ	NUP	—	—	220	220	252	263	283	400	—	—	4	4	57.1
NU2340EM	NU	NJ	NUP	—	—	220	220	247	263	283	400	—	—	4	4	99.3
NU1044	NU	NJ	—	N	—	233	233	247	254	—	327	327	313	2.5	2.5	18.2
N 244	—	—	—	N	NF	236	—	—	—	—	384	—	—	3	3	37
NU244	NU	NJ	NUP	—	—	236	236	264	273	289	384	—	—	3	3	37.3
NU2244	NU	—	—	—	—	—	236	264	273	289	384	—	—	3	3	61.8
N 344	—	—	—	N	—	240	—	—	—	—	440	—	—	4	4	72.8
NU344	NU	NJ	—	—	—	240	240	278	287	307	440	—	—	4	4	74.6

- Notes** (1) When L-shaped thrust collars (Refer to page B105) are used, the bearings become the NH Type.
 (2) If axial loads are applied, increase d_a and reduce D_a from the values listed above.
 (3) d_b (max.) are values for adjusting rings for NU, NJ Types.

SINGLE-ROW CYLINDRICAL ROLLER BEARINGS

Bore Diameter 240 – 500 mm

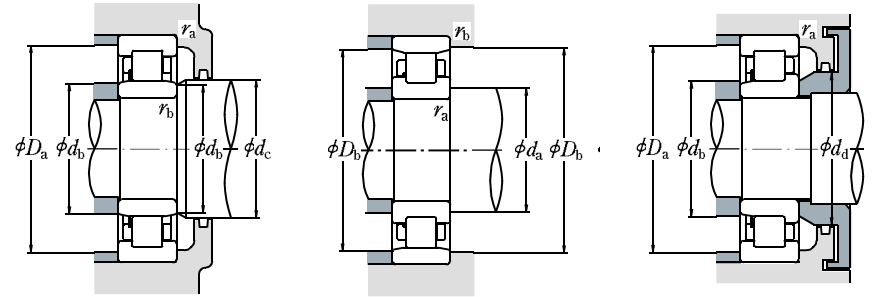
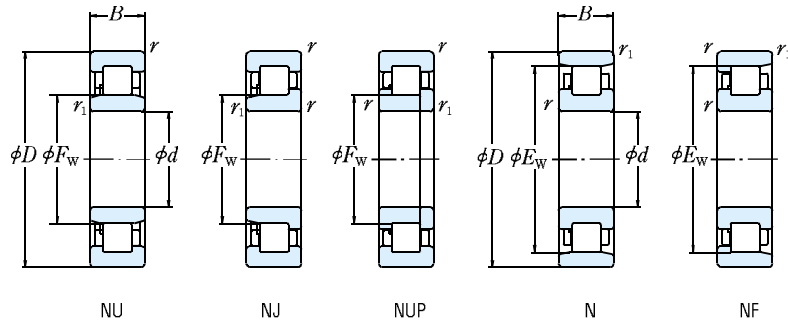

d	Boundary Dimensions (mm)						Basic Load Ratings (N)		Limiting Speeds (min ⁻¹)	
	D	B	r min.	r ₁ min.	F _W	E _W	C _r	C _{0r}	Grease	Oil
240	360	56	3	3	270	330	530 000	820 000	1 600	2 000
	440	72	4	4	—	385	935 000	1 340 000	1 300	1 600
	440	72	4	4	295	—	935 000	1 340 000	1 300	1 600
	440	120	4	4	295	—	1 440 000	2 320 000	1 200	1 500
	500	95	5	5	—	430	1 360 000	1 820 000	1 100	1 300
260	400	65	4	4	296	364	645 000	1 000 000	1 500	1 800
	480	80	5	5	—	420	1 100 000	1 580 000	1 200	1 500
	480	80	5	5	320	—	1 100 000	1 580 000	1 200	1 500
	480	130	5	5	320	—	1 710 000	2 770 000	1 100	1 300
	540	102	6	6	336	—	1 540 000	2 090 000	1 000	1 200
280	420	65	4	4	316	384	660 000	1 050 000	1 400	1 700
	500	80	5	5	—	440	1 140 000	1 680 000	1 100	1 400
	500	80	5	5	340	—	1 140 000	1 680 000	1 100	1 400
300	460	74	4	4	340	420	885 000	1 400 000	1 300	1 500
	540	85	5	5	364	—	1 400 000	2 070 000	1 100	1 300
320	480	74	4	4	360	440	905 000	1 470 000	1 200	1 400
	580	92	5	5	—	510	1 540 000	2 270 000	950	1 200
	580	92	5	5	390	—	1 540 000	2 270 000	950	1 200
340	520	82	5	5	385	475	1 080 000	1 740 000	1 100	1 300
360	540	82	5	5	405	495	1 110 000	1 830 000	1 000	1 300
380	560	82	5	5	425	—	1 140 000	1 910 000	1 000	1 200
400	600	90	5	5	450	550	1 360 000	2 280 000	900	1 100
420	620	90	5	5	470	570	1 390 000	2 380 000	850	1 100
440	650	94	6	6	493	—	1 470 000	2 530 000	800	1 000
460	680	100	6	6	516	624	1 580 000	2 740 000	750	950
480	700	100	6	6	536	644	1 620 000	2 860 000	750	900
500	720	100	6	6	556	664	1 660 000	2 970 000	710	850

Bearing Numbers	Abutment and Fillet Dimensions (mm)										Mass (kg) approx.					
	NU	NJ	NUP	N	NF	d _a ⁽²⁾ min.	d _b min.	d _b ⁽³⁾ max.	d _c min.	d _a min.		D _a ⁽²⁾ max.	D _b max.	D _b min.	r _a max.	r _b max.
NU1048	NU	NJ	—	N	—	253	253	266	275	—	347	347	333	2.5	2.5	19.5
N 248	—	—	—	N	NF	256	—	—	—	—	—	424	392	3	3	49.6
NU 248	NU	NJ	NUP	—	—	256	256	289	298	316	424	—	—	3	3	50.4
NU2248	NU	—	—	—	—	—	256	289	298	316	424	—	—	3	3	84.9
N 348	—	—	—	N	—	260	—	—	—	—	—	480	438	4	4	92.3
NU 348	NU	NJ	—	—	—	260	260	304	313	333	480	—	—	4	4	94.6
NU1052	NU	NJ	—	N	NF	276	276	292	300	—	384	384	367	3	3	29.1
N 252	—	—	—	N	—	280	—	—	—	—	—	460	428	4	4	66.2
NU 252	NU	NJ	—	—	—	280	280	314	323	343	460	—	—	4	4	67.1
NU2252	NU	—	NUP	—	—	280	280	314	323	343	460	—	—	4	4	111
NU 352	NU	NJ	—	—	—	286	286	330	339	359	514	—	—	5	5	118
NU1056	NU	NJ	NUP	N	NF	296	296	312	320	—	404	404	387	3	3	30.8
N 256	—	—	—	N	NF	300	—	—	—	—	—	480	448	4	4	69.6
NU 256	NU	NJ	—	—	—	300	300	334	344	364	480	—	—	4	4	70.7
NU1060	NU	NJ	—	N	NF	316	316	336	344	—	444	444	424	3	3	43.7
NU 260	NU	NJ	—	—	—	320	320	358	368	391	520	—	—	4	4	89.2
NU1064	NU	—	—	N	NF	336	336	356	365	—	464	464	444	3	3	46.1
N 264	—	—	—	N	—	340	—	—	—	—	—	560	519	4	4	110
NU 264	NU	NJ	—	—	—	340	340	384	394	420	560	—	—	4	4	112
NU1068	NU	NJ	—	N	NF	360	360	381	390	—	500	500	479	4	4	61.8
NU1072	NU	—	—	N	NF	380	380	400	410	—	520	520	499	4	4	64.6
NU1076	NU	—	—	—	—	—	400	420	430	—	540	—	—	4	4	67.5
NU1080	NU	—	NUP	N	—	420	420	445	455	—	580	580	554.5	4	4	88.2
NU1084	NU	—	—	N	—	440	440	465	475	—	600	600	574.5	4	4	91.7
NU1088	NU	—	—	—	—	—	466	488	498	—	624	—	—	5	5	105
NU1092	NU	—	NUP	N	—	486	486	511	521	—	654	654	628.5	5	5	123
NU1096	NU	NJ	—	N	—	506	506	531	541	—	674	674	654	5	5	127
NU10/500	NU	—	—	N	—	526	526	551	558	—	694	694	674	5	5	131

- Notes** (1) When L-shaped thrust collars (Refer to page B105) are used, the bearings become the NH Type.
 (2) If axial loads are applied, increase d_a and reduce D_a from the values listed above.
 (3) d_b (max.) are values for adjusting rings for NU, NJ Types.

CYLINDRICAL ROLLER BEARINGS

L-Shaped Thrust Collars
Bore Diameter 20 – 85 mm

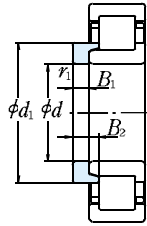

L-Shaped Thrust Collar

d	Boundary Dimensions (mm)					Bearing Numbers	Mass (kg) approx.
	d ₁	B ₁	B ₂	r ₁ min.			
20	30	3	6.75	0.6	HJ 204	0.012	
	29.8	3	5.5	0.6	HJ 204 E	0.011	
	30	3	7.5	0.6	HJ 2204	0.012	
25	29.8	3	6.5	0.6	HJ 2204 E	0.012	
	31.7	4	7.5	0.6	HJ 304	0.017	
	31.4	4	6.5	0.6	HJ 304 E	0.017	
	31.8	4	8.5	0.6	HJ 2304	0.017	
	31.4	4	7.5	0.6	HJ 2304 E	0.018	
30	34.8	3	6	0.6	HJ 205 E	0.014	
	34.8	3	6.5	0.6	HJ 2205 E	0.014	
	38.2	4	7	1.1	HJ 305 E	0.025	
	38.2	4	8	1.1	HJ 2305 E	0.026	
35	43.6	6	10.5	1.5	HJ 405	0.057	
	41.3	4	7	0.6	HJ 206 E	0.025	
	41.4	4	7.5	0.6	HJ 2206 E	0.025	
40	45.1	5	8.5	1.1	HJ 306 E	0.042	
	45.1	5	9.5	1.1	HJ 2306 E	0.043	
	50.5	7	11.5	1.5	HJ 406	0.080	
	48.2	4	7	0.6	HJ 207 E	0.033	
45	48.2	4	8.5	0.6	HJ 2207 E	0.035	
	51.1	6	9.5	1.1	HJ 307 E	0.060	
	51.1	6	11	1.1	HJ 2307 E	0.062	
50	59	8	13	1.5	HJ 407	0.12	
	54.1	5	8.5	1.1	HJ 208 E	0.049	
	54.1	5	9	1.1	HJ 2208 E	0.050	
55	57.6	7	11	1.5	HJ 308 E	0.088	
	57.7	7	12.5	1.5	HJ 2308 E	0.091	
	64.8	8	13	2	HJ 408	0.14	
	59.1	5	8.5	1.1	HJ 209 E	0.055	
60	59.1	5	9	1.1	HJ 2209 E	0.055	
	64.5	7	11.5	1.5	HJ 309 E	0.11	
	64.5	7	13	1.5	HJ 2309 E	0.113	
65	71.7	8	13.5	2	HJ 409	0.175	
	64.1	5	9	1.1	HJ 210 E	0.061	
70	64.1	5	9	1.1	HJ 2210 E	0.061	
	71.4	8	13	2	HJ 310 E	0.151	
	71.4	8	14.5	2	HJ 2310 E	0.155	
75	78.8	9	14.5	2.1	HJ 410	0.23	
	70.9	6	9.5	1.1	HJ 211 E	0.087	
80	70.9	6	10	1.1	HJ 2211 E	0.088	
	77.6	9	14	2	HJ 311 E	0.195	
	77.6	9	15.5	2	HJ 2311 E	0.20	
85	85.2	10	16.5	2.1	HJ 411	0.29	
	77.7	6	10	1.5	HJ 212 E	0.108	
	77.7	6	10	1.5	HJ 2212 E	0.108	
90	84.5	9	14.5	2.1	HJ 312 E	0.231	
	84.5	9	16	2.1	HJ 2312 E	0.237	
	91.8	10	16.5	2.1	HJ 412	0.34	
95	84.5	6	10	1.5	HJ 213 E	0.129	
	84.5	6	10.5	1.5	HJ 2213 E	0.131	
	90.6	10	15.5	2.1	HJ 313 E	0.288	
100	90.6	10	18	2.1	HJ 2313 E	0.298	
	98.5	11	18	2.1	HJ 413	0.42	
	89.5	7	11	1.5	HJ 214 E	0.157	
105	89.5	7	11.5	1.5	HJ 2214 E	0.158	
	97.5	10	15.5	2.1	HJ 314 E	0.33	
	97.5	10	18.5	2.1	HJ 2314 E	0.345	
110	110.5	12	20	3	HJ 414	0.605	
	94.5	7	11	1.5	HJ 215 E	0.166	
	94.5	7	11.5	1.5	HJ 2215 E	0.167	
115	104.2	11	16.5	2.1	HJ 315 E	0.41	
	104.2	11	19.5	2.1	HJ 2315 E	0.43	
	116	13	21.5	3	HJ 415	0.71	
120	101.6	8	12.5	2	HJ 216 E	0.222	
	101.6	8	12.5	2	HJ 2216 E	0.222	
	110.6	11	17	2.1	HJ 316 E	0.46	
125	110.6	11	20	2.1	HJ 2316 E	0.48	
	122	13	22	3	HJ 416	0.78	
	107.6	8	12.5	2	HJ 217 E	0.25	
130	107.6	8	13	2	HJ 2217 E	0.252	
	117.9	12	18.5	3	HJ 317 E	0.575	
	117.9	12	22	3	HJ 2317 E	0.595	
135	126	14	24	4	HJ 417	0.88	
	114.3	9	14	2	HJ 218 E	0.32	
140	114.3	9	15	2	HJ 2218 E	0.325	
	124.2	12	18.5	3	HJ 318 E	0.63	
	124.2	12	22	3	HJ 2318 E	0.66	
145	137	14	24	4	HJ 418	1.05	
	120.6	9	14	2.1	HJ 219 E	0.355	
	120.6	9	15.5	2.1	HJ 2219 E	0.365	
150	132.2	13	20.5	3	HJ 319 E	0.785	
	132.2	13	24.5	3	HJ 2319 E	0.815	
	147	15	25.5	4	HJ 419	1.3	
155	127.5	10	15	2.1	HJ 220 E	0.44	
	127.5	10	16	2.1	HJ 2220 E	0.45	
	139.6	13	20.5	3	HJ 320 E	0.89	
160	139.6	13	23.5	3	HJ 2320 E	0.92	
	153.5	16	27	4	HJ 420	1.5	
	145	13	20.5	3	HJ 312 E	0.97	
165	159.5	16	27	4	HJ 421	1.65	
	141.7	11	17	2.1	HJ 222 E	0.62	
	141.7	11	19.5	2.1	HJ 2222 E	0.645	
170	155.8	14	22	3	HJ 322 E	1.21	
	155.8	14	26.5	3	HJ 2322 E	1.27	
	171	17	29.5	4	HJ 422	2.1	
175	153.4	11	17	2.1	HJ 224 E	0.71	
	153.4	11	20	2.1	HJ 2224 E	0.745	
	168.6	14	22.5	3	HJ 324 E	1.41	
180	168.6	14	26	3	HJ 2324 E	1.46	
	188	17	30.5	5	HJ 424	2.6	
	164.2	11	17	3	HJ 226 E	0.79	
185	164.2	11	21	3	HJ 2226 E	0.84	
	182.3	14	23	4	HJ 326 E	1.65	
	182.3	14	28	4	HJ 2326 E	1.73	
190	205	18	32	5	HJ 426	3.3	
	180	11	18	3	HJ 228 E	0.99	
	180	11	23	3	HJ 2228 E	1.07	
195	196	15	25	4	HJ 328 E	2.04	
	196	15	31	4	HJ 2328 E	2.14	
	219	18	33	5	HJ 428	3.75	

Bore Diameter 90~320 mm

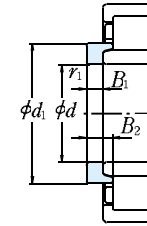

L-Shaped Thrust Collar

d	Boundary Dimensions (mm)					Bearing Numbers	Mass (kg) approx.
	d ₁	B ₁	B ₂	r ₁ min.			
90	114.3	9	14	2	HJ 218 E	0.32	
	114.3	9	15	2	HJ 2218 E	0.325	
	124.2	12	18.5	3	HJ 318 E	0.63	
95	124.2	12	22	3	HJ 2318 E	0.66	
	137	14	24	4	HJ 418	1.05	
	120.6	9	14	2.1	HJ 219 E	0.355	
100	120.6	9	15.5	2.1	HJ 2219 E	0.365	
	132.2	13	20.5	3	HJ 319 E	0.785	
	132.2	13	24.5	3	HJ 2319 E	0.815	
105	147	15	25.5	4	HJ 419	1.3	
	127.5	10	15	2.1	HJ 220 E	0.44	
	127.5	10	16	2.1	HJ 2220 E	0.45	
110	139.6	13	20.5	3	HJ 320 E	0.89	
	139.6	13	23.5	3	HJ 2320 E	0.92	
	153.5	16	27	4	HJ 420	1.5	
115	145	13	20.5	3	HJ 312 E	0.97	
	159.5	16	27	4	HJ 421	1.65	
	141.7	11	17	2.1	HJ 222 E	0.62	
120	141.7	11	19.5	2.1	HJ 2222 E	0.645	
	155.8	14	22	3	HJ 322 E	1.21	
	155.8	14	26.5	3	HJ 2322 E	1.27	
125	171	17	29.5	4	HJ 422	2.1	
	153.4	11	17	2.1	HJ 224 E	0.71	
	153.4	11	20	2.1	HJ 2224 E	0.745	
130	168.6	14	22.5	3	HJ 324 E	1.41	
	168.6	14	26	3	HJ 2324 E	1.46	
	188	17	30.5	5	HJ 424	2.6	
135	164.2	11	17	3	HJ 226 E	0.79	
	164.2	11	21	3	HJ 2226 E	0.84	
	182.3	14	23	4	HJ 326 E	1.65	
140	182.3	14	28	4	HJ 2326 E	1.73	
	205	18	32	5	HJ 426	3.3	
	180	11	18	3	HJ 228 E	0.99	
145	180	11	23	3	HJ 2228 E	1.07	
	196	15	25	4	HJ 328 E	2.04	
	196	15	31	4	HJ 2328 E	2.14	
150	219	18	33	5	HJ 428	3.75	

d	Boundary Dimensions (mm)					Bearing Numbers	Mass (kg) approx.
	d ₁	B ₁	B ₂	r ₁ min.			
150	193.7	12	19.5	3	HJ 230 E	1.26	
	193.7	12	24.5	3	HJ 2230 E	1.35	
	210	15	25	4	HJ 330 E	2.35	
155	210	15	31.5	4	HJ 2330 E	2.48	
	234	20	36.5	5	HJ 430	4.7	
	207.3	12	20	3	HJ 232 E	1.48	
160	206.1	12	24.5	3	HJ 2232 E	1.55	
	222	15	25	4	HJ 332 E	2.59	
	222.1	15	32	4	HJ 2332 E	2.76	
165	220.8	12	20	4	HJ 234 E	1.7	
	219.5	12	24	4	HJ 2234 E	1.79	
	238	16	33.5	4	HJ 434 E	3.25	
170	230.8	12	20	4	HJ 236 E	1.79	
	229.5	12	24	4	HJ 2236 E	1.88	
	252	17	35	4	HJ 436 E	3.85	
175	244.5	13	21.5	4	HJ 238 E	2.19	
	243.2	13	26.5	4	HJ 2238 E	2.31	
	260.6	18	36.5	5	HJ 438 E	4.45	
180	258.2	14	23	4	HJ 240 E	2.65	
	258	14	34	4	HJ 2240 E	2.6	
	256.9	14	28	4	HJ 2240 E	2.78	
185	280	18	30	5	HJ 440 E	5.0	
	286	15	27.5				

DOUBLE-ROW CYLINDRICAL ROLLER BEARINGS

Bore Diameter 25 – 140 mm

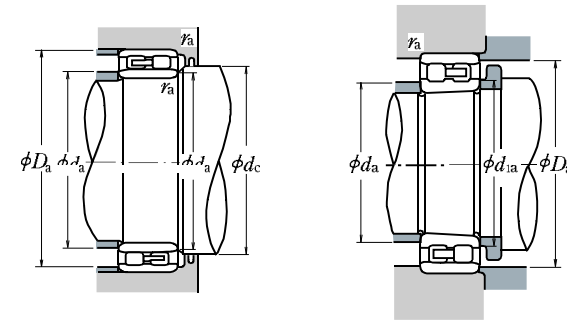
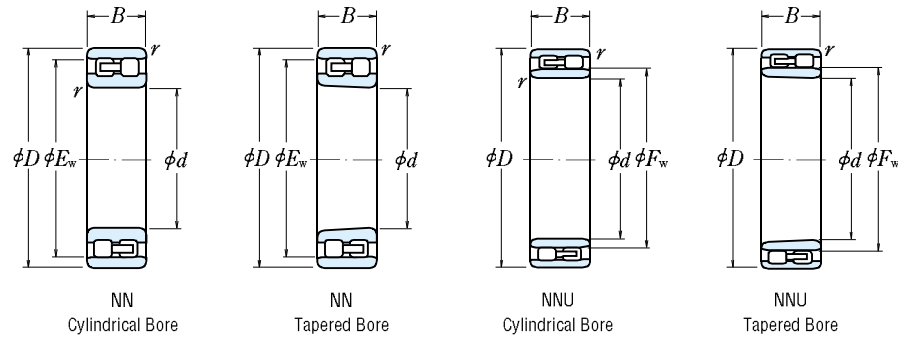

<i>d</i>	Boundary Dimensions (mm)					Basic Load Ratings (N)		Limiting Speeds (min ⁻¹)	
	<i>D</i>	<i>B</i>	<i>r</i> _{min.}	<i>F</i> _w	<i>E</i> _w	<i>C</i> _r	<i>C</i> _{0r}	Grease	Oil
25	47	16	0.6	—	41.3	25 800	30 000	14 000	17 000
30	55	19	1	—	48.5	31 000	37 000	12 000	14 000
35	62	20	1	—	55	39 500	50 000	10 000	12 000
40	68	21	1	—	61	43 500	55 500	9 000	11 000
45	75	23	1	—	67.5	52 000	68 500	8 500	10 000
50	80	23	1	—	72.5	53 000	72 500	7 500	9 000
55	90	26	1.1	—	81	69 500	96 500	6 700	8 000
60	95	26	1.1	—	86.1	73 500	106 000	6 300	7 500
65	100	26	1.1	—	91	77 000	116 000	6 000	7 100
70	110	30	1.1	—	100	97 500	148 000	5 600	6 700
75	115	30	1.1	—	105	96 500	149 000	5 300	6 300
80	125	34	1.1	—	113	119 000	186 000	4 800	6 000
85	130	34	1.1	—	118	125 000	201 000	4 500	5 600
90	140	37	1.5	—	127	143 000	228 000	4 300	5 000
95	145	37	1.5	—	132	150 000	246 000	4 000	5 000
100	140	40	1.1	112	—	155 000	295 000	4 000	5 000
	150	37	1.5	—	137	157 000	265 000	4 000	4 800
105	145	40	1.1	117	—	161 000	315 000	3 800	4 800
	160	41	2	—	146	198 000	320 000	3 800	4 500
110	150	40	1.1	122	—	167 000	335 000	3 600	4 500
	170	45	2	—	155	229 000	375 000	3 400	4 300
120	165	45	1.1	133.5	—	183 000	360 000	3 200	4 000
	180	46	2	—	165	239 000	405 000	3 200	3 800
130	180	50	1.5	144	—	274 000	545 000	3 000	3 800
	200	52	2	—	182	284 000	475 000	3 000	3 600
140	190	50	1.5	154	—	283 000	585 000	2 800	3 600
	210	53	2	—	192	298 000	515 000	2 800	3 400

Note (1) The suffix K represents bearings with tapered bores (taper 1 : 12).

Remarks Production of double-row cylindrical roller bearings is generally in the high precision classes (Class 5 or better).

Bearing Numbers		Abutment and Fillet Dimensions (mm)						Mass (kg)	
Cylindrical Bore	Tapered Bore ⁽¹⁾	<i>d</i> _a ⁽²⁾ min.	<i>d</i> _a ⁽²⁾ max.	<i>d</i> _{1a} min.	<i>d</i> _c min.	<i>D</i> _a max.	<i>r</i> _a min.	<i>r</i> _a max.	approx.
NN 3005	NN 3005 K	29	—	29	—	43	42	0.6	0.127
NN 3006	NN 3006 K	35	—	36	—	50	50	1	0.198
NN 3007	NN 3007 K	40	—	41	—	57	56	1	0.258
NN 3008	NN 3008 K	45	—	46	—	63	62	1	0.309
NN 3009	NN 3009 K	50	—	51	—	70	69	1	0.407
NN 3010	NN 3010 K	55	—	56	—	75	74	1	0.436
NN 3011	NN 3011 K	61.5	—	62	—	83.5	83	1	0.647
NN 3012	NN 3012 K	66.5	—	67	—	88.5	88	1	0.693
NN 3013	NN 3013 K	71.5	—	72	—	93.5	93	1	0.741
NN 3014	NN 3014 K	76.5	—	77	—	103.5	102	1	1.06
NN 3015	NN 3015 K	81.5	—	82	—	108.5	107	1	1.11
NN 3016	NN 3016 K	86.5	—	87	—	118.5	115	1	1.54
NN 3017	NN 3017 K	91.5	—	92	—	123.5	120	1	1.63
NN 3018	NN 3018 K	98	—	99	—	132	129	1.5	2.09
NN 3019	NN 3019 K	103	—	104	—	137	134	1.5	2.19
NNU 4920	NNU 4920 K	106.5	111	108	115	133.5	—	1	1.9
NN 3020	NN 3020 K	108	—	109	—	142	139	1.5	2.28
NNU 4921	NNU 4921 K	111.5	116	113	120	138.5	—	1	1.99
NN 3021	NN 3021 K	114	—	115	—	151	148	2	2.88
NNU 4922	NNU 4922 K	116.5	121	118	125	143.5	—	1	2.07
NN 3022	NN 3022 K	119	—	121	—	161	157	2	3.71
NNU 4924	NNU 4924 K	126.5	133	128	137	158.5	—	1	2.85
NN 3024	NN 3024 K	129	—	131	—	171	167	2	4.04
NNU 4926	NNU 4926 K	138	143	140	148	172	—	1.5	3.85
NN 3026	NN 3026 K	139	—	141	—	191	185	2	5.88
NNU 4928	NNU 4928 K	148	153	150	158	182	—	1.5	4.08
NN 3028	NN 3028 K	149	—	151	—	201	195	2	6.34

Note (2) *d*_a (max.) are values for adjusting rings for the NNU Type.

DOUBLE-ROW CYLINDRICAL ROLLER BEARINGS

Bore Diameter 150 – 360 mm

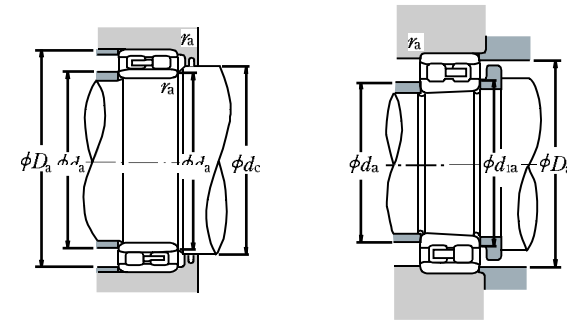
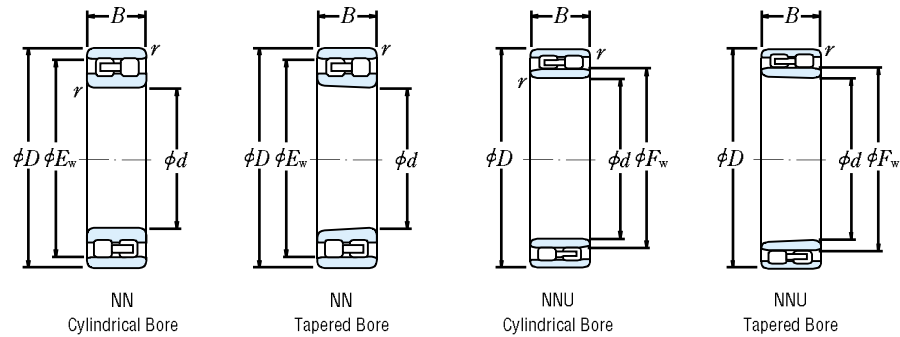

<i>d</i>	Boundary Dimensions (mm)					Basic Load Ratings (N)		Limiting Speeds (min ⁻¹)	
	<i>D</i>	<i>B</i>	<i>r</i> _{min.}	<i>F</i> _W	<i>E</i> _W	<i>C</i> _r	<i>C</i> _{0r}	Grease	Oil
150	210	60	2	167	—	350 000	715 000	2 600	3 200
	225	56	2.1	—	206	335 000	585 000	2 600	3 000
160	220	60	2	177	—	365 000	760 000	2 400	3 000
	240	60	2.1	—	219	375 000	660 000	2 400	2 800
170	230	60	2	187	—	375 000	805 000	2 400	2 800
	260	67	2.1	—	236	450 000	805 000	2 200	2 600
180	250	69	2	200	—	480 000	1 020 000	2 200	2 600
	280	74	2.1	—	255	565 000	995 000	2 000	2 400
190	260	69	2	211.5	—	485 000	1 060 000	2 000	2 600
	290	75	2.1	—	265	595 000	1 080 000	2 000	2 400
200	280	80	2.1	223	—	570 000	1 220 000	1 900	2 400
	310	82	2.1	—	282	655 000	1 170 000	1 800	2 200
220	300	80	2.1	243	—	600 000	1 330 000	1 700	2 200
	340	90	3	—	310	815 000	1 480 000	1 700	2 000
240	320	80	2.1	263	—	625 000	1 450 000	1 600	2 000
	360	92	3	—	330	855 000	1 600 000	1 500	1 800
260	360	100	2.1	289	—	935 000	2 100 000	1 400	1 800
	400	104	4	—	364	1 030 000	1 920 000	1 400	1 700
280	380	100	2.1	309	—	960 000	2 230 000	1 300	1 700
	420	106	4	—	384	1 080 000	2 080 000	1 300	1 500
300	420	118	3	336	—	1 230 000	2 870 000	1 200	1 500
	460	118	4	—	418	1 290 000	2 460 000	1 200	1 400
320	440	118	3	356	—	1 260 000	3 050 000	1 100	1 400
	480	121	4	—	438	1 350 000	2 670 000	1 100	1 300
340	520	133	5	—	473	1 670 000	3 300 000	1 000	1 200
360	540	134	5	—	493	1 700 000	3 450 000	950	1 200

Note (1) The suffix K represents bearings with tapered bores (taper 1 : 12).

Remarks Production of double-row cylindrical roller bearings is generally in the high precision classes (Class 5 or better).

Bearing Numbers		Abutment and Fillet Dimensions (mm)						Mass (kg)	
Cylindrical Bore	Tapered Bore ⁽¹⁾	<i>d</i> _a ⁽²⁾ min.	<i>d</i> _a ⁽²⁾ max.	<i>d</i> _{1a} min.	<i>d</i> _c min.	<i>D</i> _a max.	<i>r</i> _a min.	<i>r</i> _a max.	approx.
NNU 4930	NNU 4930 K	159	166	162	171	201	—	2	6.39
NN 3030	NN 3030 K	161	—	162	—	214	209	2	7.77
NNU 4932	NNU 4932 K	169	176	172	182	211	—	2	6.76
NN 3032	NN 3032 K	171	—	172	—	229	222	2	9.41
NNU 4934	NNU 4934 K	179	186	182	192	221	—	2	7.12
NN 3034	NN 3034 K	181	—	183	—	249	239	2	12.8
NNU 4936	NNU 4936 K	189	199	193	205	241	—	2	10.4
NN 3036	NN 3036 K	191	—	193	—	269	258	2	18.8
NNU 4938	NNU 4938 K	199	211	203	217	251	—	2	10.9
NN 3038	NN 3038 K	201	—	203	—	279	268	2	17.8
NNU 4940	NNU 4940 K	211	222	214	228	269	—	2	15.3
NN 3040	NN 3040 K	211	—	214	—	299	285	2	22.7
NNU 4944	NNU 4944 K	231	242	234	248	289	—	2	16.6
NN 3044	NN 3044 K	233	—	236	—	327	313	2.5	29.6
NNU 4948	NNU 4948 K	251	262	254	269	309	—	2	18
NN 3048	NN 3048 K	253	—	256	—	347	334	2.5	32.7
NNU 4952	NNU 4952 K	271	288	275	295	349	—	2	31.1
NN 3052	NN 3052 K	276	—	278	—	384	368	3	47.7
NNU 4956	NNU 4956 K	291	308	295	315	369	—	2	33
NN 3056	NN 3056 K	296	—	298	—	404	388	3	51.1
NNU 4960	NNU 4960 K	313	335	318	343	407	—	2.5	51.9
NN 3060	NN 3060 K	316	—	319	—	444	422	3	70.7
NNU 4964	NNU 4964 K	333	355	338	363	427	—	2.5	54.9
NN 3064	NN 3064 K	336	—	340	—	464	442	3	76.6
NN 3068	NN 3068 K	360	—	365	—	500	477	4	102
NN 3072	NN 3072 K	380	—	385	—	520	497	4	106

Note (2) *d*_a (max.) are values for adjusting rings for the NNU Type.